

3-Port Atmospherically Referenced

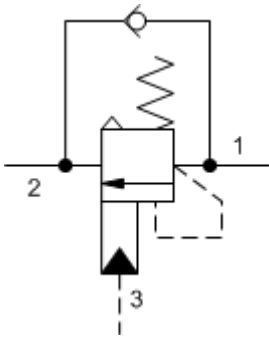

3-Port Atmospherically Referenced, Non-adjustable

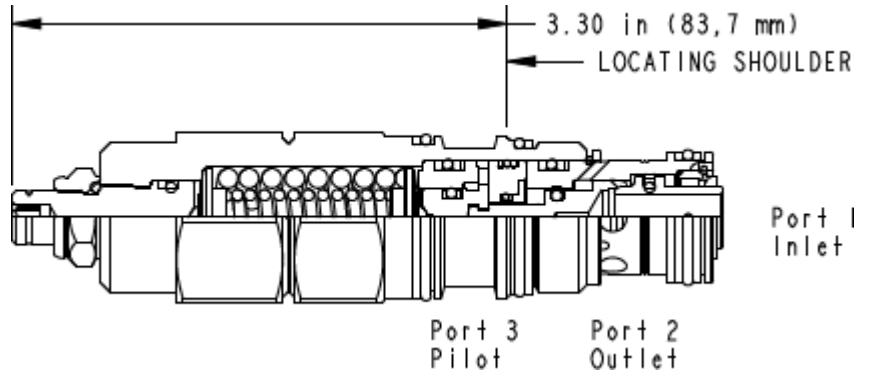

TECHNICAL DATA NOTE: DATA MAY VARY BY CONFIGURATION. SEE CONFIGURATION SECTION.

Pilot Ratio	3:1
Maximum Recommended Load Pressure at Maximum Setting	215 bar
Maximum Setting	280 bar
Adjustment - No. of CCW Turns from Min. to Max. Setting	5
Check Cracking Pressure	1,7 bar
Factory Pressure Settings Established at	30 cc/min.
Maximum Valve Leakage at Reseat	0,3 cc/min.
Reseat	>85% of setting
Locknut Hex Size	15 mm
Locknut Torque	9 - 10 Nm
Seal kit - Cartridge	Buna: 990-302-007
Seal kit - Cartridge	Viton: 990-302-006
Seal kit - Cartridge	Buna: 990-302-007
Seal kit - Cartridge	Viton: 990-302-006

CONFIGURATION OPTIONS

Model Code Example: CAEALHN

CONTROL	(L)	FUNCTIONAL SETTING RANGE	(H)	SEAL MATERIAL	(N)	MATERIAL/COATING
L Standard Screw Adjustment		H 1000 - 4000 psi (70 - 280 bar), 3000 psi (210 bar) Standard Setting		N Buna-N		Standard Material/Coating
C Tamper Resistant - Factory Set		I 400 - 1500 psi (28 - 105 bar), 1000 psi (70 bar) Standard Setting		V Viton		/AP Stainless Steel, Passivated /LH Mild Steel, Zinc-Nickel