

3-Port Atmospherically Referenced

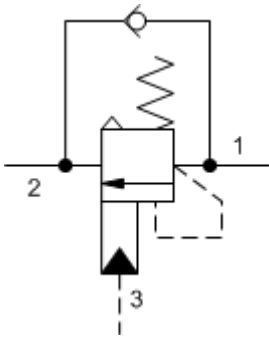

3-Port Atmospherically Referenced, Non-adjustable

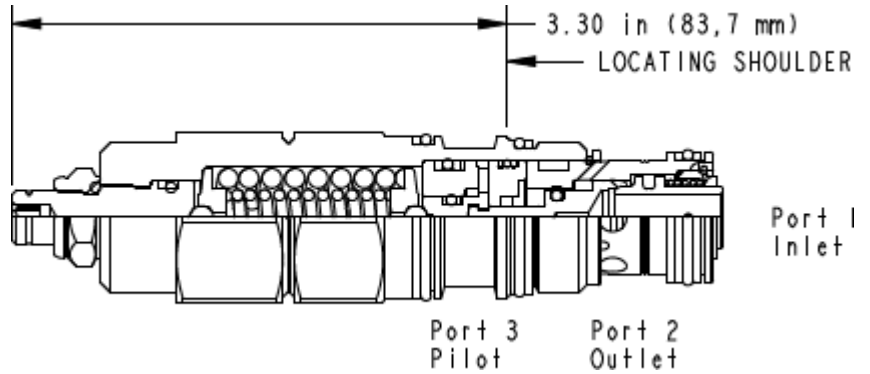

TECHNICAL DATA NOTE: DATA MAY VARY BY CONFIGURATION. SEE CONFIGURATION SECTION.

Pilot Ratio	2:1
Maximum Recommended Load Pressure at Maximum Setting	320 bar
Maximum Setting	420 bar
Adjustment - No. of CCW Turns from Min. to Max. Setting	5
Check Cracking Pressure	1,7 bar
Factory Pressure Settings Established at	30 cc/min.
Maximum Valve Leakage at Reseat	0,3 cc/min.
Reseat	>85% of setting
Locknut Hex Size	15 mm
Locknut Torque	9 - 10 Nm
Seal kit - Cartridge	Buna: 990-302-007
Seal kit - Cartridge	Viton: 990-302-006
Seal kit - Cartridge	Buna: 990-302-007
Seal kit - Cartridge	Viton: 990-302-006

CONFIGURATION OPTIONS

Model Code Example: CAELGN

CONTROL

(L)

FUNCTIONAL SETTING RANGE

(G)

SEAL MATERIAL

(N)

L Standard Screw Adjustment

C Tamper Resistant - Factory Set

G 2000 - 6000 psi (140 - 420 bar), 4000 psi (280 bar) Standard Setting

F 1000 - 2500 psi (70 - 175 bar), 2000 psi (140 bar) Standard Setting

N Buna-N

V Viton