

3-Port Atmospherically Referenced

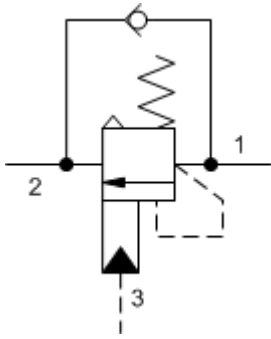

3-Port Atmospherically Referenced, Non-adjustable

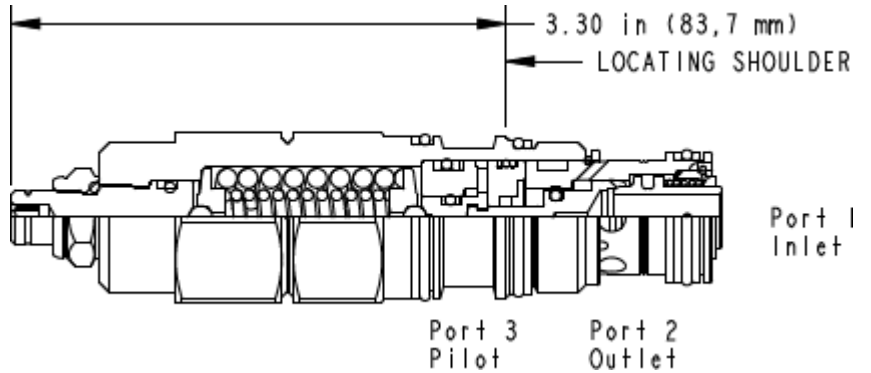

Atmospherically vented counterbalance valves with pilot assist are meant to control an overrunning load. The check valve allows free flow from the directional valve (port 2) to the load (port 1) while a direct-acting, pilot-assisted relief valve controls flow from port 1 to port 2. Pilot assist at port 3 lowers the effective setting of the relief valve at a rate determined by the pilot ratio. Backpressure at port 2 does not affect the valve setting because the spring chamber is atmospherically referenced. Other names for this valve include motion control valve and over-center valve.

TECHNICAL DATA NOTE: DATA MAY VARY BY CONFIGURATION. SEE CONFIGURATION SECTION.

Cavity	T-2A
Series	2
Capacity	30 gpm
Pilot Ratio	2:1
Maximum Recommended Load Pressure at Maximum Setting	4615 psi
Maximum Setting	6000 psi
Adjustment - No. of CCW Turns from Min. to Max. Setting	5
Check Cracking Pressure	25 psi
Factory Pressure Settings Established at	2 in ³ /min.
Maximum Valve Leakage at Reseat	5 drops/min.
Operating Characteristic	Standard
Reseat	>85% of setting
Valve Hex Size	1 1/8 in.
Valve Installation Torque	45 - 50 lbf ft
Adjustment Screw Internal Hex Size	5/32 in.
Locknut Hex Size	9/16 in.
Locknut Torque	80 - 90 lbf in.
Model Weight	0.83 lb.
Seal kit - Cartridge	Buna: 990-302-007
Seal kit - Cartridge	Viton: 990-302-006

OPTION SELECTION EXAMPLE: CAELGN

CONTROL	(L) FUNCTIONAL SETTING RANGE	(G) SEAL MATERIAL	(N)
L Standard Screw Adjustment C Tamper Resistant - Factory Set	G 2000 - 6000 psi (140 - 420 bar), 4000 psi (280 bar) Standard Setting F 1000 - 2500 psi (70 - 175 bar), 2000 psi (140 bar) Standard Setting	N Buna-N V Viton	

TECHNICAL FEATURES

- Counterbalance valves should be set at least 1.3 times the maximum load induced pressure.
- Turn adjustment clockwise to decrease setting and release load.
- Full clockwise setting is 200 psi (14 bar).
- Approximately 1 drop (0,07 cc) of fluid will pass from the pilot area to the vented spring chamber every 4000 cycles.
- Reseat exceeds 85% of set pressure when the valve is standard set. Settings lower than the standard set pressure may result in lower reseal percentages.
- Sun counterbalance cartridges can be installed directly into a cavity machined in an actuator housing for added protection and improved stiffness in the circuit.
- This valve has positive seals between all ports.
- With vented valves, a lower pilot ratio may be required to achieve machine stability compared to non-vented valves.
- Three-port vented valves are atmospherically referenced and considered problem solvers for existing circuits using non-vented valves. Over time, the vented valves may leak externally or allow moisture into the spring chamber. Four-port vented counterbalance valves are recommended for new applications.
- All 3-port counterbalance, load control, and pilot-to-open check cartridges are physically interchangeable (i.e. same flow path, same cavity for a given frame size).
- Incorporates the Sun floating style construction to minimize the possibility of internal parts binding due to excessive installation torque and/or cavity/cartridge machining variations.

PERFORMANCE CURVES

