

3-Port Non-vented, Fixed Setting

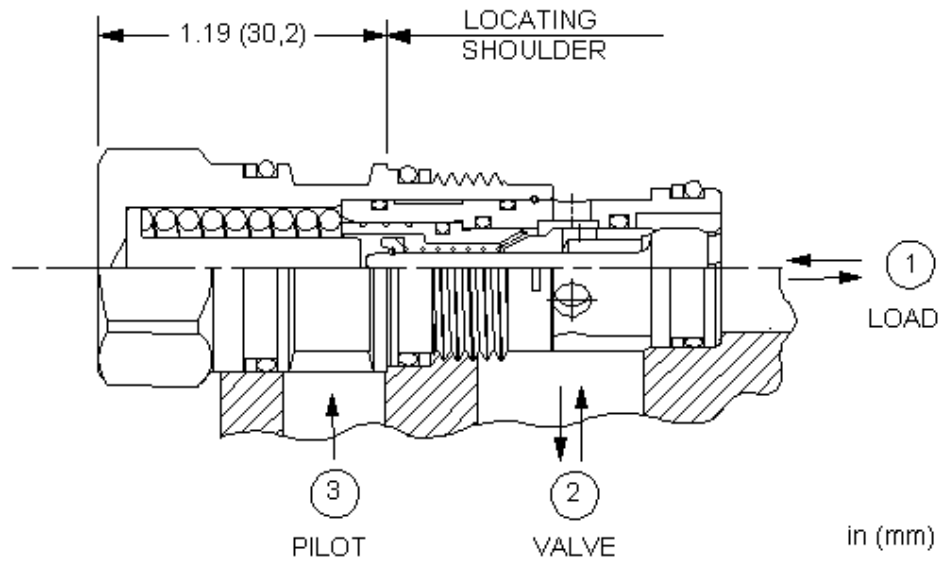

CONFIGURATION

M	Fixed Pressure Range	4700 - 5600 psi (325 - 390 bar)
N	Seal Material	Buna-N
	Material/Coating	

Fixed-setting, 3-port counterbalance valves with pilot-assist function similarly to the adjustable versions except the fixed setting is pre-set to a nominal value. These fixed-setting valves are meant to control an overrunning load. The check valve allows free flow from the directional valve (port 2) to the load (port 1) while a direct-acting, pilot-assisted relief valve controls flow from port 1 to port 2. Pilot assist at port 3 lowers the effective setting of the relief valve at a rate determined by the pilot ratio. Other names for this valve include motion control valve and over-center valve.

TECHNICAL DATA NOTE: DATA MAY VARY BY CONFIGURATION. SEE CONFIGURATION SECTION.

Cavity	T-11A
Series	1
Capacity	10 gpm
Pilot Ratio	2.3:1
Maximum Recommended Load Pressure	See Technical Features
Check Cracking Pressure	25 psi
Factory Pressure Settings Established at	2 in ³ /min.
Maximum Valve Leakage at Reseat	5 drops/min.
Operating Characteristic	Semi-restrictive
Valve Hex Size	7/8 in.
Valve Installation Torque	30 - 35 lbf ft
Model Weight	0.27 lb.
Seal kit - Cartridge	Buna: 990-011-007
Seal kit - Cartridge	Polyurethane: 990-011-002
Seal kit - Cartridge	Viton: 990-011-006

OPTION SELECTION EXAMPLE: CBBLXMN

FIXED PRESSURE RANGE	(M) SEAL MATERIAL	(N) MATERIAL/COATING
M 4700 - 5600 psi (325 - 390 bar)	N Buna-N	Standard Material/Coating
V 3200 - 3800 psi (220 - 260 bar)	V Viton	/LH Mild Steel, Zinc-Nickel
X 3500 - 4200 psi (245 - 290 bar)		
Z 4125 - 4900 psi (285 - 340 bar)		

TECHNICAL FEATURES

- The maximum recommended load pressure for the M range is 3600 psi (250 bar). The highest cracking pressure for the M range will be less than 5600 psi (390 bar).
- The maximum recommended load pressure for the V range is 2450 psi (170 bar). The highest cracking pressure for the V range will be less than 3800 psi (260 bar).
- The maximum recommended load pressure for the X range is 2700 psi (190 bar). The highest cracking pressure for the X range will be less than 4200 psi (290 bar).
- The maximum recommended load pressure for the Z range is 3170 psi (220 bar). The highest cracking pressure for the Z range will be less than 4900 psi (340 bar).
- Note: The pressures listed under RANGE are approximate, mean values and should not be used for inspection purposes.
- Note: The percentage difference between the cracking and reseal values for the fixed and adjustable versions of this valve are identical. However, the cracking point for the adjustable control can be set via the adjustment mechanism to within +/- 50 psi (3,5 bar) of the specified value. In the case of the fixed-setting version, the setting tolerance can only be maintained within a several hundred psi span, depending on the range. The maximum recommended load pressure for any given range is the minimum possible setting divided by 1.3.
- Fixed-setting counterbalance valves offer a shorter cartridge extension than the adjustable version.
- Fixed-setting counterbalance valves can be used to protect cylinder seals in outrigger circuits from damage due to thermal expansion, however, they probably should not be applied in circuits in which a matched valve setting may be required such as dual cylinder applications.
- All 3-port counterbalance, load control, and pilot-to-open check cartridges are physically interchangeable (i.e. same flow path, same cavity for a given frame size).
- This valve has positive seals between all ports.
- Backpressure at port 2 adds to the effective relief setting at a ratio of 1 plus the pilot ratio times the backpressure.
- Incorporates the Sun floating style construction to minimize the possibility of internal parts binding due to excessive installation torque and/or cavity/cartridge machining variations.

PERFORMANCE CURVES

