

3-Port Non-vented, Fixed Setting

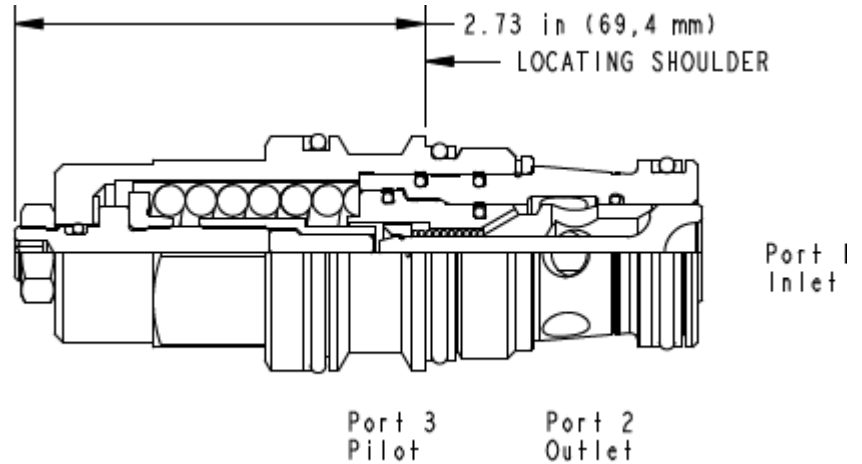

Counterbalance valves with pilot assist are meant to control an overrunning load. The check valve allows free flow from the directional valve (port 2) to the load (port 1) while a direct-acting, pilot-assisted relief valve controls flow from port 1 to port 2. Pilot assist at port 3 lowers the effective setting of the relief valve at a rate determined by the pilot ratio. Other names for this valve include motion control valve and over-center valve.

TECHNICAL DATA NOTE: DATA MAY VARY BY CONFIGURATION. SEE CONFIGURATION SECTION.

Cavity	T-17A
Series	3
Capacity	60 gpm
Pilot Ratio	3:1
Maximum Recommended Load Pressure at Maximum Setting	3075 psi
Maximum Setting	4000 psi
Adjustment - No. of CCW Turns from Min. to Max. Setting	3.75
Factory Pressure Settings Established at	2 in ³ /min.
Maximum Valve Leakage at Reseat	5 drops/min.
Operating Characteristic	Standard
Reseat	>85% of setting
Valve Hex Size	1 1/4 in.
Valve Installation Torque	150 - 160 lbf ft
Adjustment Screw Internal Hex Size	5/32 in.
Locknut Hex Size	9/16 in.
Locknut Torque	80 - 90 lbf in.
Model Weight	1.36 lb.
Seal kit - Cartridge	Buna: 990-017-007
Seal kit - Cartridge	EPDM: 990-017-014
Seal kit - Cartridge	Polyurethane: 990-017-002
Seal kit - Cartridge	Viton: 990-017-006

OPTION SELECTION EXAMPLE: CBGALHN

CONTROL	(L) FUNCTIONAL SETTING RANGE	(H) SEAL MATERIAL	(N) MATERIAL/COATING
L Standard Screw Adjustment C Tamper Resistant - Factory Set	H 1000 - 4000 psi w/25 psi Check (70 - 280 bar w/ 1,7 bar Check), 3000 psi (210 bar) Standard Setting A 1000 - 4000 psi w/4 psi Check (70 - 280 bar w/ 0,3 bar Check), 3000 psi (210 bar) Standard Setting B 400 - 1500 psi w/4 psi Check (28 - 105 bar w/ 0,3 bar Check), 1000 psi (70 bar) Standard Setting I 400 - 1500 psi w/25 psi Check (28 - 105 bar w/ 1,7 bar Check), 1000 psi (70 bar) Standard Setting	N Buna-N E EPDM V Viton	Standard Material/Coating /AP Stainless Steel, Passivated /LH Mild Steel, Zinc-Nickel

TECHNICAL FEATURES

- Counterbalance valves should be set at least 1.3 times the maximum load induced pressure.
- Turn adjustment clockwise to decrease setting and release load.
- Full clockwise setting is less than 200 psi (14 bar).
- Backpressure at port 2 adds to the effective relief setting at a ratio of 1 plus the pilot ratio times the backpressure.
- Reseat exceeds 85% of set pressure when the valve is standard set. Settings lower than the standard set pressure may result in lower reseal percentages.
- Cartridges configured with EPDM seals are for use in systems with phosphate ester fluids. Exposure to petroleum based fluids, greases and lubricants will damage the seals.
- Sun counterbalance cartridges can be installed directly into a cavity machined in an actuator housing for added protection and improved stiffness in the circuit.
- Two check valve cracking pressures are available. Use the 25 psi (1,7 bar) check unless actuator cavitation is a concern.
- This valve has positive seals between all ports.
- All 3-port counterbalance, load control, and pilot-to-open check cartridges are physically interchangeable (i.e. same flow path, same cavity for a given frame size).
- Incorporates the Sun floating style construction to minimize the possibility of internal parts binding due to excessive installation torque and/or cavity/cartridge machining variations.

PERFORMANCE CURVES

