

CONFIGURATION

M

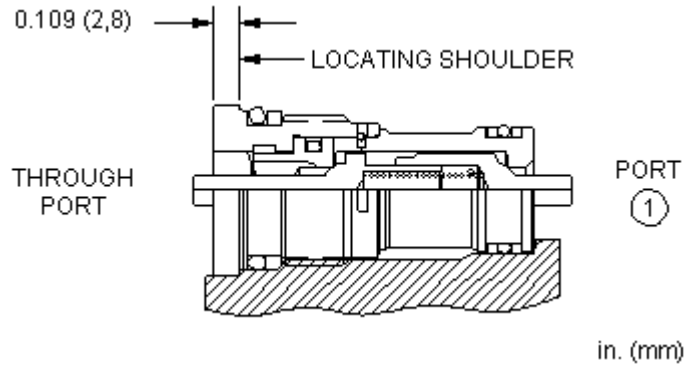

TECHNICAL DATA NOTE: DATA MAY VARY BY CONFIGURATION. SEE CONFIGURATION SECTION.

	T-162DP
	0
	4,7 L/min.
	350 bar
110 SUS (24 cSt)	0,07 cc/min.
	8 mm
	27 - 33 Nm
Seal kit - Cartridge	Buna: 990-162-007
Seal kit - Cartridge	Polyurethane: 990-162-002
Seal kit - Cartridge	Viton: 990-162-006
Seal kit - Cartridge	Buna: 990-162-007
Seal kit - Cartridge	Polyurethane: 990-162-002
Seal kit - Cartridge	Viton: 990-162-006

: •

998-101

OPTION SELECTION EXAMPLE: CDAQMN

(M)

(C)

(V)

M

C 30 psi (2 bar)

V

N

TECHNICAL FEATURES

- 5°
-
-
- 0.047in 1.2mm
- T-162A 2
-
-
-
-
- 1 0.07cc/min
- Sun

PERFORMANCE CURVES

