

### CONFIGURATION

Control
Cracking Pressure
Seal Material

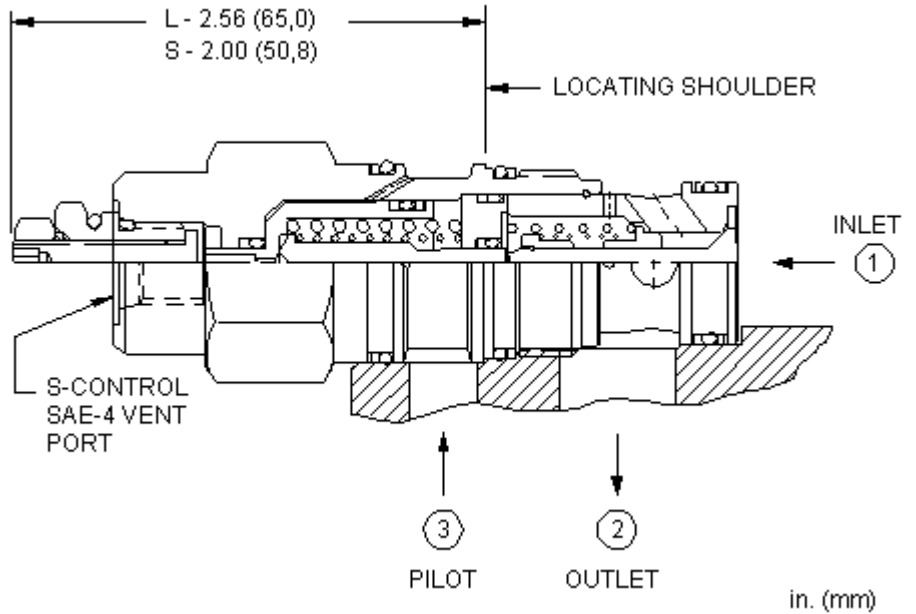

This valve is a pilot to open check valve. It has a sealed pilot, a steel seat, and is vented. It allows free flow from the valve (port 2) to the load (port 1) and blocks flow in the opposite direction. Pressure at the pilot (port 3) pilot port will open the valve from port 1 to port 2. Pilot pressure needed to open the valve is directly proportional to the load pressure at port 1. The valve is insensitive to pressure at port 2 because the spring chamber is referenced out the back of the hex body.

### TECHNICAL DATA NOTE: DATA MAY VARY BY CONFIGURATION. SEE CONFIGURATION SECTION.

Cavity	T-2A
Series	2
Capacity	30 gpm
Maximum Operating Pressure	5000 psi
Pilot Ratio	3:1
Maximum Valve Leakage at 110 SUS (24 cSt)	1 drops/min.
Valve Hex Size	1 1/8 in.
Valve Installation Torque	45 - 50 lbf ft
Adjustment Screw Internal Hex Size	1/8 in.
Locknut Hex Size	7/16 in.
Model Weight	.50 lb
Seal kit - Cartridge	Buna: 990-202-007
Seal kit - Cartridge	Polyurethane: 990-002-002
Seal kit - Cartridge	Viton: 990-202-006

## OPTION SELECTION EXAMPLE: CKEVCN

CONTROL	(S) CRACKING PRESSURE	(F) SEAL MATERIAL
<b>S</b> External 4- <small>SAE</small> Vent Port	<b>F</b> 100 psi (7 bar)	<b>V</b> Viton
X Standard Pilot, Atmospheric Vent	A 4 psi (0,3 bar)	N Buna-N
	B 15 psi (1 bar)	
	C 30 psi (2 bar)	
	D 50 psi (3,5 bar)	
	E 75 psi (5 bar)	

### TECHNICAL FEATURES

- There is a positive seal between ports 2 and 3.
- Pilot pressure as low as 75 psi (5 bar) higher than the pressure at the vent can prevent the valve from closing.
- Atmospherically referenced pilot-to-open check valves are considered problem solvers for existing circuits using non-vented valves. However, the atmospherically referenced valve will eventually leak externally or allow moisture into the spring chamber. Four-port vented pilot-to-open check cartridges are recommended for new applications.
- Pilot-to-open check cartridges are locking valves, not motion control valves. For motion control applications, use counterbalance valves.
- Approximately 1 drop (0,07 cc) of fluid will pass from the pilot area to the vented spring chamber every 4000 cycles.
- For models with manual load release control option, turn load release clockwise to release load.
- Provides hose break protection, prevents loads from drifting and positively locks pressurized loads.
- Extremely low leakage. The seat and poppet are heat treated for long life. If the load drifts due to the valve, the seat has probably been damaged by contamination and the valve should be replaced.
- Sealed pilot for use in circuits where cross port leakage is undesirable.
- Incorporates the Sun floating style construction to minimize the possibility of internal parts binding due to excessive installation torque and/or cavity/cartridge machining variations.

### PERFORMANCE CURVES

