

CONFIGURATION

X	Control	piloto estándar
C	Cracking Pressure	30 psi (2 bar)
N	Seal Material	Buna-N
	Material/Coating	

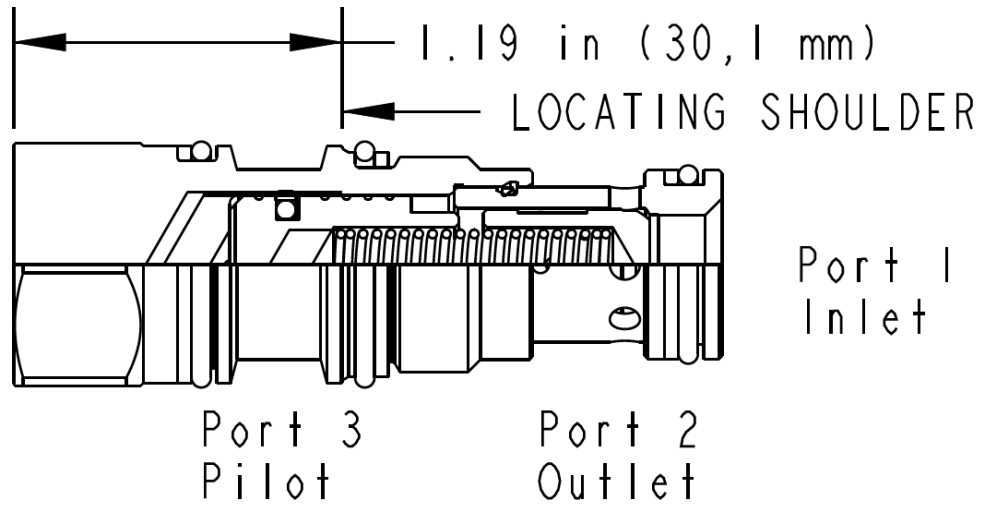

TECHNICAL DATA NOTE: DATA MAY VARY BY CONFIGURATION. SEE CONFIGURATION SECTION.

cavidad	T-11A
Series	1
Capacity	80 L/min.
Maximum Operating Pressure	350 bar
Pilot Ratio	1.8:1
Maximum Valve Leakage at 110 SUS (24 cSt)	0,07 cc/min.
Valve Hex Size	22,2 mm
Valve Installation Torque	41 - 47 Nm
Model Weight	0.13 kg.
Seal kit - Cartridge	Buna: 990-011-007
Seal kit - Cartridge	EPDM: 990-011-014
Seal kit - Cartridge	Polyurethane: 990-011-002
Seal kit - Cartridge	Viton: 990-011-006
Seal kit - Cartridge	Buna: 990-011-007
Seal kit - Cartridge	EPDM: 990-011-014
Seal kit - Cartridge	Polyurethane: 990-011-002
Seal kit - Cartridge	Viton: 990-011-006

OPTION SELECTION EXAMPLE: CODAXCN

CONTROL	(X)	CRACKING PRESSURE	(C)	SEAL MATERIAL	(N)	MATERIAL/COATING	(/LH)
X piloto estándar		C 30 psi (2 bar)		N Buna-N		/LH Mild Steel, Zinc-Nickel	
L activador manual		F 100 psi (7 bar)		E EPDM		/AP Stainless Steel, Passivated	
		G 150 psi (10,5 bar)		V Viton		Standard Material/Coating	
		Z 1 psi (0,07 bar)					

PERFORMANCE CURVES

