

CONFIGURATION

X	
E	75 psi (5 bar)
N	
Material/Coating	

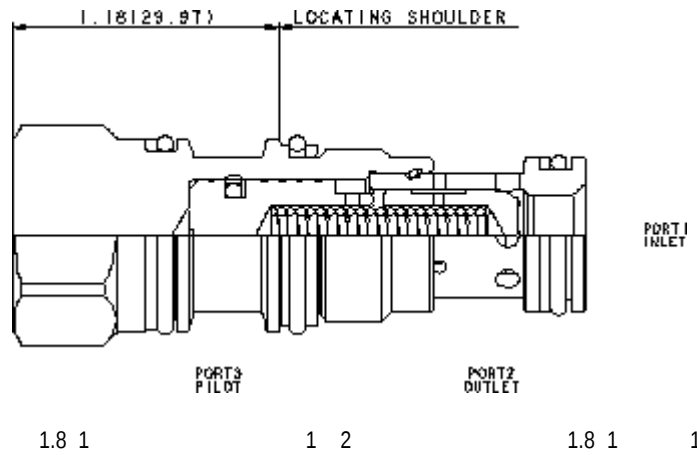

TECHNICAL DATA NOTE: DATA MAY VARY BY CONFIGURATION. SEE CONFIGURATION SECTION.

	T-11A
	1
	80 L/min.
	350 bar
	1.8:1
110 SUS (24 cSt)	0,07 cc/min.
	22,2 mm
	41 - 47 Nm
	0.13 kg.
Seal kit - Cartridge	Buna: 990-011-007
Seal kit - Cartridge	EPDM: 990-011-014
Seal kit - Cartridge	Polyurethane: 990-011-002
Seal kit - Cartridge	Viton: 990-011-006

OPTION SELECTION EXAMPLE: CODAXEN

	(X)	(E)	(N)	MATERIAL/COATING	(/LH)
X	E	75 psi (5 bar)	N	/LH	-
	A	4 psi (0,3 bar)	E	EPDM	/AP
	B	15 psi (1 bar)	V		Standard Material/Coating
	C	30 psi (2 bar)			
	D	50 psi (3,5 bar)			
	F	100 psi (7 bar)			
	G	150 psi (10,5 bar)			

TECHNICAL FEATURES

-
- 1.8:1 1000psi 70bar 1800psi 125bar 1
- 2
- 2 1
-
- CO*A CO*B CO*A CO*A
- EPDM
- "/AP"
- Sun

PERFORMANCE CURVES

