

CONFIGURATION

X	Control	Standard Pilot
C	Spool Configuration	Blocked Center
	Seal Material	

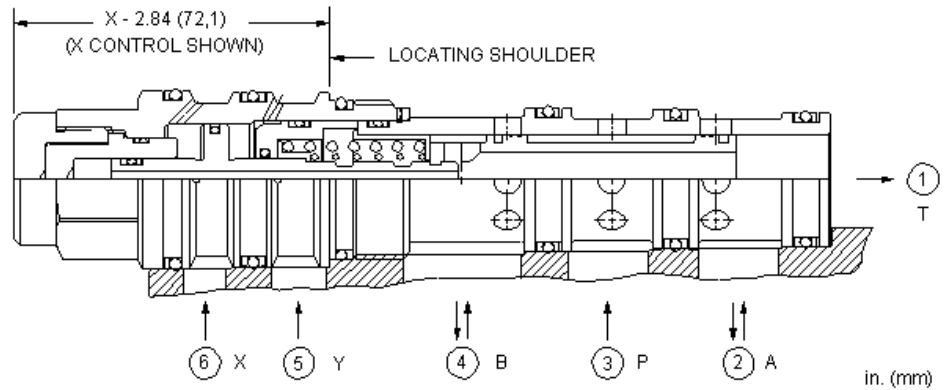

Two-position, 4-way directional cartridges are spring-offset, 6-port directional valves that can be configured from a choice of 9 different spool options. The supply port is port 3 and all ports will accept 5000 psi (350 bar). Capacity for these pilot-to-shift valves is dependent on the spool type specified.

TECHNICAL DATA NOTE: DATA MAY VARY BY CONFIGURATION. SEE CONFIGURATION SECTION.

Cavity	T-63A
Series	3
Capacity	25 - 100 gpm
Minimum Pilot Pressure Required to Shift Valve	125 psi
Maximum Valve Leakage at 110 SUS (24 cSt)	2 in ³ /min. @1000 psi
Pilot Volume Displacement	.17 in ³
Valve Hex Size	1 1/4 in.
Valve Installation Torque	150 - 160 lbf ft
Seal kit - Cartridge	Buna: 990-063-007
Seal kit - Cartridge	EPDM: 990-063-014
Seal kit - Cartridge	Polyurethane: 990-063-002
Seal kit - Cartridge	Viton: 990-063-006

OPTION SELECTION EXAMPLE: DCEFXCXYN

CONTROL	(X) SPOOL CONFIGURATION	(C) SEAL MATERIAL	(N)
X Standard Pilot	C Blocked Center	N Buna-N	
	A A to T Center	E EPDM	
	B B to T Center	V Viton	
	H Open Center		
	R Regen Center		
	T Tandem Center		
	W A and B Bleed to T Center		
	X P to A and B to T Center		
	Y A and B to T Center		

TECHNICAL FEATURES

- All ports will accept 5000 psi (350 bar), including the x and y pilot ports (port 5 and port 6).
- The reason for the different capacities, or performance limits, for the different spool configurations are flow forces. Flow forces are proportional to flow and pressure drop. Typically, they resist the opening of a passage. Spool configurations that open passages as they spring center are the most susceptible. If the flow forces due to the flow and pressure conditions exceed the centering spring force the valve may not shift completely. Higher flows may be used at lower pressures.
- Leakage listed in technical data is for each path.
- The pilot ports, 5 and 6, are positively sealed from the work ports.
- Cartridges configured with EPDM seals are for use in systems with phosphate ester fluids. Exposure to petroleum based fluids, greases and lubricants will damage the seals.
- Hardened spool and sleeve provide consistent and low spool leakage rates and excellent wear characteristics.
- Incorporates the Sun floating-style construction to minimize the possibility of internal parts binding due to excessive installation torque and/or cavity/cartridge machining variations.

PERFORMANCE CURVES

