

X-Control, C-Poppet

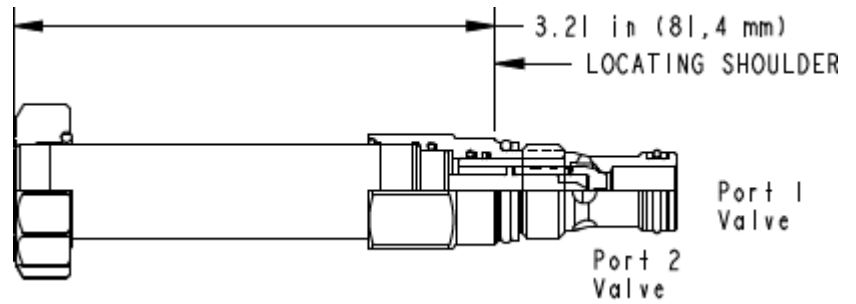

FLeX 2 2

2 1 2 1

1 2

TECHNICAL DATA NOTE: DATA MAY VARY BY CONFIGURATION. SEE CONFIGURATION SECTION.

	T-162A
	0
	40 L/min.
	210 bar
110 SUS (24 cSt)	0,07 cc/min.@210 bar
	3,5 bar
	2,8 - 380 cSt
	50 ms
	15,000 max. cycles/hr
	19,1 mm
	27 - 33 Nm
	0.18 kg.
Seal kit - Cartridge	Buna: 990-162-007
Seal kit - Cartridge	Viton: 990-162-006
Seal kit - Cartridge	Buna: 990-162-007
Seal kit - Cartridge	Viton: 990-162-006

- : • Sun
- 2.00 inches (50,8 mm)

OPTION SELECTION EXAMPLE: DFBDXCN

	(X)	(C)	(N)
X	C	N	
D /	H	E EPDM	
L		V	
M			
P			
T ()			

TECHNICAL FEATURES

- EPDM
- 1000
- NFPA T2.6.1 R2014
-
- CFD
- - 1000
- IP69K
- - 0.004 in³ (0.07 cc³)/min (1 /min)
- FLeX
-
- P
- D L
-
-
- Sun /

PERFORMANCE CURVES

