

X-Control, C-Poppet

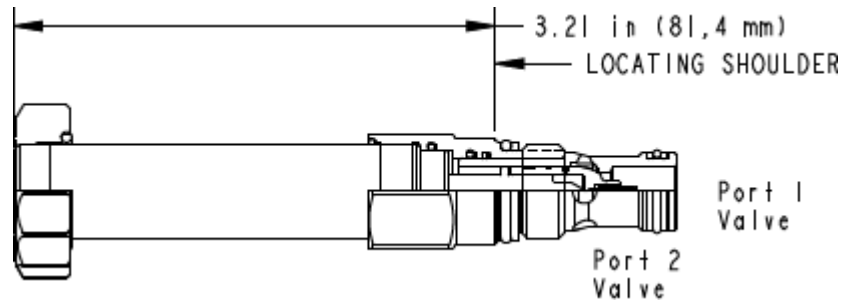

TECHNICAL DATA NOTE: DATA MAY VARY BY CONFIGURATION. SEE CONFIGURATION SECTION.

Maximum Operating Pressure	210 bar
Check Cracking Pressure	3,5 bar
Maximum Valve Leakage at 110 SUS (24 cSt)	0,07 cc/min.@210 bar
Viscosity Range	2,8 - 380 cSt
Response Time - Typical	50 ms
Switching Frequency	15,000 max. cycles/hr
Seal kit - Cartridge	Buna: 990-162-007
Seal kit - Cartridge	Viton: 990-162-006
Seal kit - Cartridge	Buna: 990-162-007
Seal kit - Cartridge	Viton: 990-162-006

CONFIGURATION OPTIONS

Model Code Example: DFBEXCN

CONTROL	(X)	POPPET CONFIGURATION	(C)	SEAL MATERIAL	(N)	BOBINA
X No Manual Override		C normalmente cerrado		N Buna-N		No coil
D Twist/Lock (Dual) Manual Override		H normalmente abierto		E EPDM		
L Twist/Lock (Detent) Manual Override				V Viton		
M activador manual						
P Manual Pull Override						
T Twist (Momentary) Manual Override						