

X-Control, C-Poppet

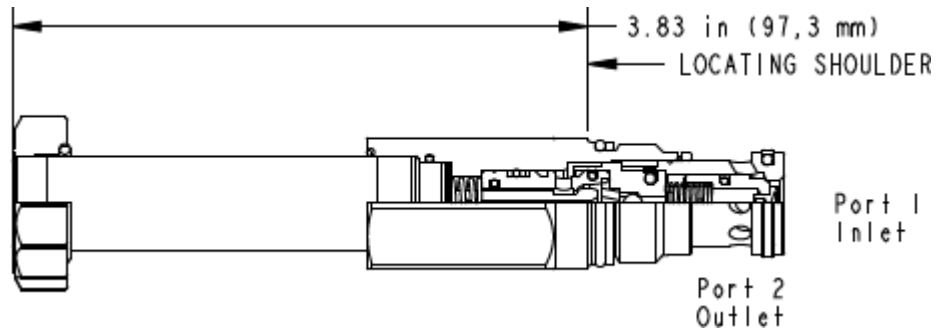

TECHNICAL DATA NOTE: DATA MAY VARY BY CONFIGURATION. SEE CONFIGURATION SECTION.

cavidad	T-13A
Series	1
Capacity	60 L/min.
Maximum Operating Pressure	350 bar
Check Cracking Pressure	3,5 bar
Maximum Valve Leakage at 110 SUS (24 cSt)	0,7 cc/min.@350 bar
Response Time - Typical	30 ms
Switching Frequency	15,000 max. cycles/hr
Solenoid Tube Diameter	16 mm
Valve Hex Size	22,2 mm
Valve Installation Torque	41 - 47 Nm
Model Weight	0.28 kg.
Seal kit - Cartridge	Buna: 990-310-007
Seal kit - Cartridge	EPDM: 990-310-014
Seal kit - Cartridge	Viton: 990-310-006

OPTION SELECTION EXAMPLE: DFCIXCN

CONTROL	(X)	SPOOL CONFIGURATION	(C)	SEAL MATERIAL	(N)	BOBINA
X No Manual Override		C normalmente cerrado		N Buna-N		No coil
D Twist/Lock (Dual) Manual Override		H normalmente abierto		E EPDM		
L Twist/Lock (Detent) Manual Override				V Viton		
M activador manual						
T Twist (Momentary) Manual Override						

PERFORMANCE CURVES

