

X-Control, C-Poppet

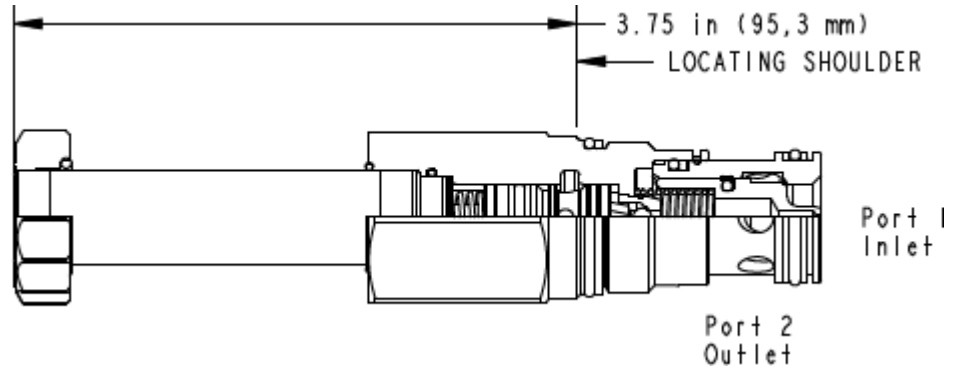

This solenoid controlled, 2-way, 2-position cartridge is a pilot-operated, poppet style directional valve with reverse free flow check. It is available in either a normally open or normally closed configuration. Due to its poppet style construction, it has extremely low leakage. This valve is designed to be used with 740 and 747 Series coils.

TECHNICAL DATA NOTE: DATA MAY VARY BY CONFIGURATION. SEE CONFIGURATION SECTION.

Maximum Operating Pressure	5000 psi
Check Cracking Pressure	50 psi
Maximum Valve Leakage at 110 SUS (24 cSt)	10 drops/min. @5000 psi
Response Time - Typical	30 ms
Switching Frequency	15,000 max. cycles/hr
Seal kit - Cartridge	Buna: 990-203-007
Seal kit - Cartridge	EPDM: 990-203-014
Seal kit - Cartridge	Viton: 990-203-006

- NOTES:**
- Please verify cartridge clearance requirements when choosing a Sun manifold. Different valve controls and coils require different clearances.
 - An additional 2.00 inches (50,8 mm) beyond the valve extension is needed for coil installation and removal.

CONFIGURATION OPTIONS

Model Code Example: DFDIXCN

CONTROL	(X)	SPOOL CONFIGURATION	(C)	SEAL MATERIAL	(N)	COIL *
X No Manual Override		C Normally Closed		N Buna-N		No coil
D Twist/Lock (Dual) Manual Override		H Normally Open		E EPDM		* Additional coil options are available
L Twist/Lock (Detent) Manual Override				V Viton		
M Manual Override						
T Twist (Momentary) Manual Override						