

X-Control, C-Poppet

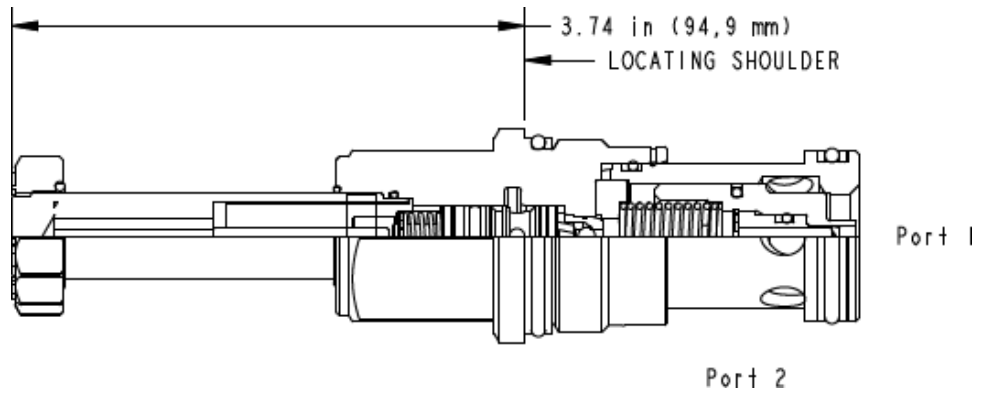

TECHNICAL DATA NOTE: DATA MAY VARY BY CONFIGURATION. SEE CONFIGURATION SECTION.

Seal kit - Cartridge	Buna: 990-016-007
Seal kit - Cartridge	EPDM: 990-016-014
Seal kit - Cartridge	Viton: 990-016-006

CONFIGURATION OPTIONS

Model Code Example: DFEIXCN

CONTROL	(X)	SPOOL CONFIGURATION	(C)	SEAL MATERIAL	(N)	BOBINA
X No Manual Override		C normalmente cerrado		N Buna-N		No coil
D Twist/Lock (Dual) Manual Override		H normalmente abierto		E EPDM		
L Twist/Lock (Detent) Manual Override				V Viton		
M activador manual						
T Twist (Momentary) Manual Override						