

X-Control, N-Spool

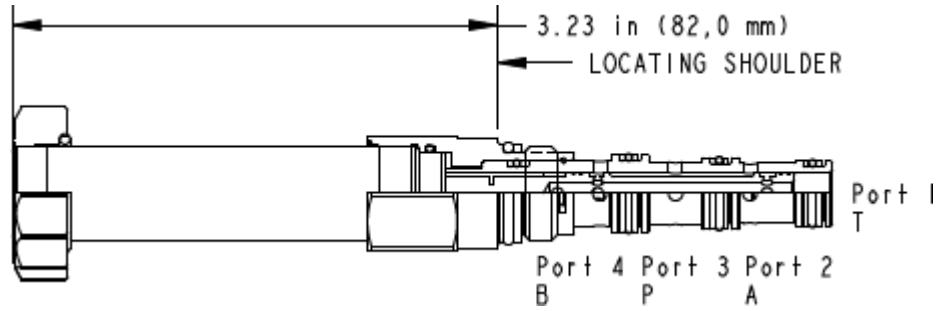

TECHNICAL DATA NOTE: DATA MAY VARY BY CONFIGURATION. SEE CONFIGURATION SECTION.

cavidad	T-30A
Series	0
Capacity	15 L/min.
Maximum Operating Pressure	350 bar
Typical Valve Leakage at 110 SUS (24 cSt) - Except N Spool	66 cc/min.@350 bar
Typical Valve Leakage at 110 SUS (24 cSt) - N Spool, Inlet on 3	115 cc/min.@350 bar
Response Time - Typical	50 ms
Switching Frequency	15,000 max. cycles/hr
Solenoid Tube Diameter	16 mm
Valve Hex Size	19,1 mm
Valve Installation Torque	35 - 40 Nm
Model Weight	0.20 kg.
Seal and nut kit - Coil	Viton: 990-740-006
Seal kit - Cartridge	Buna: 990-030-007
Seal kit - Cartridge	Viton: 990-030-006
Seal kit - Cartridge	Buna: 990-030-007
Seal kit - Cartridge	Viton: 990-030-006

OPTION SELECTION EXAMPLE: DNBFXNN

CONTROL	(X) SPOOL CONFIGURATION	(N) SEAL MATERIAL	(N) BOBINA
X No Manual Override	N Through, Shift to Cross	N Buna-N	No Coil
P Manual Pull Override	C Closed, Shift to Through	E EPDM	
	D Closed, Shift to Cross	V Viton	
	E Cross, Shift to Closed		
	T Tandem, Shift to Through		
	V Cross, Shift to Tandem		

PERFORMANCE CURVES

