

**CONFIGURATION**

X	Control	Mechanical Actuation
X	Spool Configuration	-
N	Seal Material	Buna-N

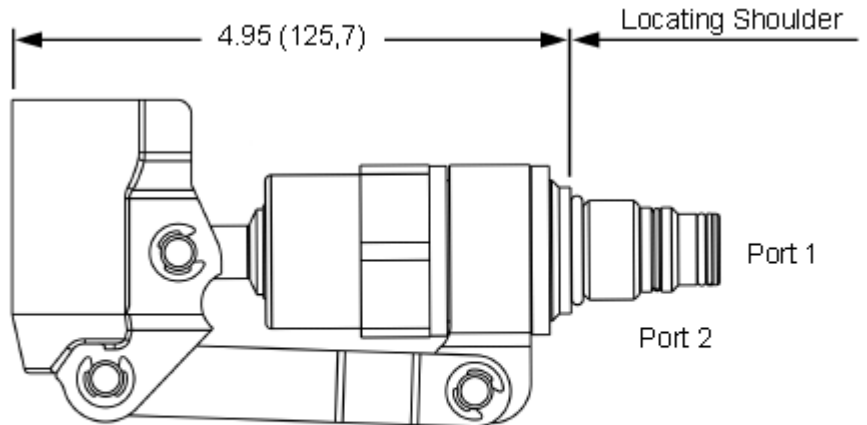

in (mm)

\*Mating handle (991-295-109)  
sold separately.  
0.84 (21,3) Dia.

This valve is a screw-in, manual hand pump cartridge with dual integrated check valves.

**TECHNICAL DATA** NOTE: DATA MAY VARY BY CONFIGURATION. SEE CONFIGURATION SECTION.

Cavity	SC-10-02
Series	1C
Capacity	.442 in <sup>3</sup>
Maximum Operating Pressure	3000 psi
Valve Hex Size	1.50 in.
Valve Installation Torque	45 - 50 lbf ft
Seal kit - Cartridge	Buna: 99C-102-007
Seal kit - Cartridge	Viton: 99C-102-006

**OPTION SELECTION EXAMPLE: HPUAXXN**

---

CONTROL	(X) SPOOL CONFIGURATION	(X) SEAL MATERIAL (N)
<b>X</b> Mechanical Actuation	<b>X</b> -	<b>N</b> Buna-N

**TECHNICAL FEATURES**

- This valve features dual integrated check valves.
- The lever socket rotates 360°.
- Zinc plated to ASTM specifications for 240 hours of salt spray resistance.
- The seat is made from hardened steel for durability.
- The mating handle is sold separately.