



MODEL
LOGCZ

Pilot-to-close, spring-biased closed, unbalanced poppet logic element with metering notches and position switch

CAPACITY: 40 gpm / CAVITY: T-17A



sunhydraulics.com/model/LOGCZ

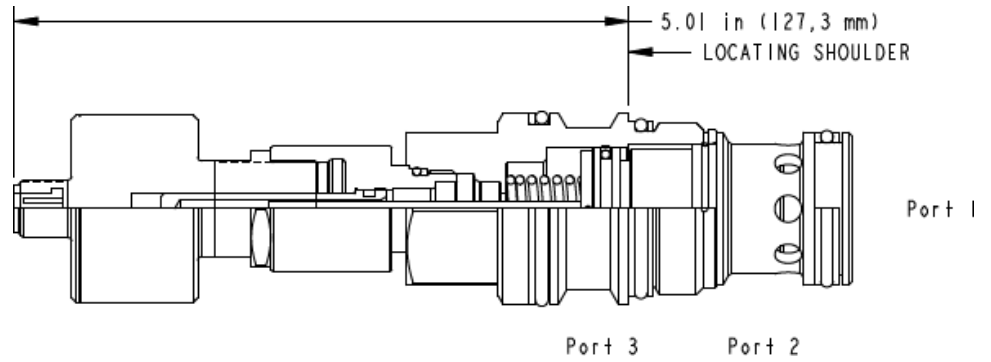
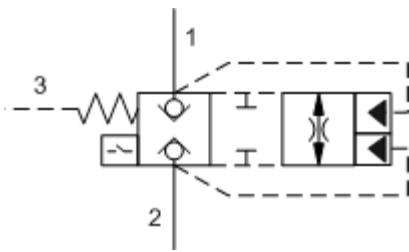

These unbalanced, pilot-to-close logic valves are 2-way switching elements that are spring biased closed. Pressure at either work port 1 or 2 will oppose the spring and tend to open the valve while pressure at port 3 will tend to close it. The force generated by the pressure at port 3, plus the spring force, must be greater than the sum of the forces generated by the pressures at ports 1 and 2 for the valve to remain closed. This valve incorporates a position switch to provide confirmation that the valve is closed.

SWITCH SPECIFICATIONS

Supply Voltage	20-30 VDC
Operating Temperature Range	-25 to 80 °C
Vibration	≥ 50g, 0-500 impulses/sec
Shock	>50 g, 1ms
Reverse Polarity Protection	Yes
Maximum Output Load	≤ 400 mA, Duty Ratio 100%
Short Circuit Protection	Yes, Load Short Unlimited
Turn On Time	≤ 25 ms
Hysteresis	≤ .002 in.
Thermal Shift - 0 to 80 °C ±	.004 in.
EMC	DIN EN 61000-6-1/2/3/4
Connector	M12 X 1 (4) Pin
Connector Environment Rating	IP65

TECHNICAL DATA NOTE: DATA MAY VARY BY CONFIGURATION. SEE CONFIGURATION SECTION.

Cavity	T-17A
Series	3
Capacity	40 gpm
Maximum Operating Pressure	5000 psi
Area Ratio, A3 to A1	1.8:1
Area Ratio, A3 to A2	2.25:1
Maximum Valve Leakage at 110 SUS (24 cSt)	1 drops/min.
Pilot Passage into Valve	.06 in.
Pilot Volume Displacement	.25 in ³
Transition leakage at 110 SUS (24 cSt)	2 in ³ /min.@1000 psi
Valve Hex Size	1 1/4 in.
Valve Installation Torque	150 - 160 lbf ft
Seal kit - Cartridge	Buna: 990-017-007
Seal kit - Cartridge	Polyurethane: 990-017-002
Seal kit - Cartridge	Viton: 990-017-006

OPTION SELECTION EXAMPLE: LOGCZDN

NOMINAL CONTROL PRESSURE

(D)

SEAL MATERIAL

(N)

D 50 psi (3,5 bar)

N Buna-N

V Viton

TECHNICAL FEATURES

- This valve has metering notches in the poppet to reduce hydraulic shock during valve opening and closing.
- The position switch in this valve provides confirmation that the valve is closed.
- These valves have positive seals between port 2 and the pilot area.
- This cartridge is supplied as a sealed, factory set unit and is not field serviceable. Any tampering will violate the product warranty.
- When torquing this cartridge into its cavity, a crow's foot wrench or similar will be required since the position switch precludes the use of a deep socket wrench.
- Because these valves are unbalanced, operation is pressure dependent. Opening and closing of the poppet are functions of the force balances on three areas: Port 1 = 100%, Port 2 = 80%, and the Pilot Area = 180%.
- These valves are pressure responsive at all ports, therefore it is essential to consider all aspects of system operation through a complete cycle. Pressure changes at any one port may cause a valve to switch from a closed to an open position, or vice versa. All possible pressure changes in the complete circuit must be considered to assure a safe, functional system design.
- All ports will accept 5000 psi (350 bar).
- Position switch is CE approved.
- An optional protective cover, with mounting hardware included, may be ordered separately. See kit number: 991-043.
- Incorporates the Sun floating style construction to minimize the possibility of internal parts binding due to excessive installation torque and/or cavity/cartridge machining variations.

PERFORMANCE CURVES

