

**CONFIGURATION**

X	Control	Not Adjustable
	Cracking Pressure	
	Seal Material	
	Material/Coating	

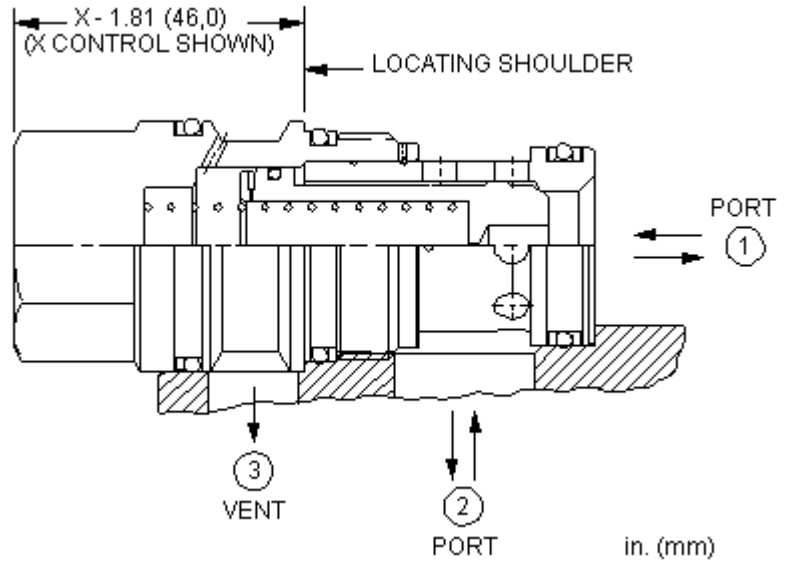

These unbalanced, vent-to-open logic valves are 2-way switching elements that are spring-biased closed and have port 1 as a pilot source. With port 3 blocked, the valve will remain in the closed position in the 1 to 2 direction and will function as a check valve from 2 to 1. With port 3 vented, the valve will open provided there is sufficient pressure to overcome the spring force. The force generated at port 3, plus the spring force, must be greater than the sum of the forces acting at port 1 and port 2 for the valve to remain closed. NOTE: The pilot area (port 3) is 1.8 times the area at port 1 and 2.25 times the area at port 2.

**TECHNICAL DATA**

Maximum Operating Pressure	5000 psi
Area Ratio, A3 to A1	1.8:1
Area Ratio, A3 to A2	2.25:1
Control Orifice Diameter	.031 in.
Pilot Volume Displacement	.25 in <sup>3</sup>
Seal kit - Cartridge	Buna: 990-017-007
Seal kit - Cartridge	Polyurethane: 990-017-002
Seal kit - Cartridge	Viton: 990-017-006

**CONFIGURATION OPTIONS**

**Model Code Example: LOHAXN**

CONTROL	(X)	CRACKING PRESSURE	(D)	SEAL MATERIAL	(V)	MATERIAL/COATING
X	Not Adjustable	D	50 psi (3,5 bar)	V	Viton	Standard Material/Coating
				N	Buna-N	IAP Stainless Steel, Passivated