

CONFIGURATION

| | |
|-------------------|----------------|
| X Control | Not Adjustable |
| Cracking Pressure | |
| Seal Material | |
| Material/Coating | |

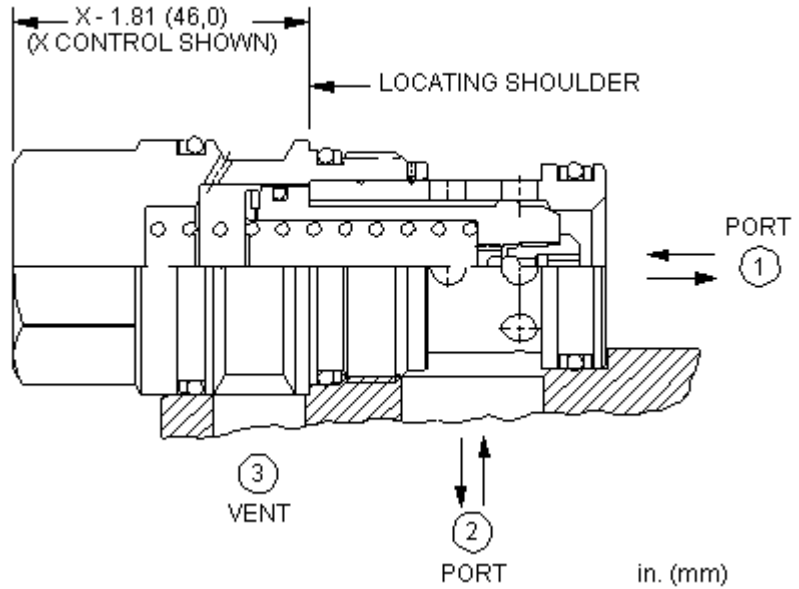

These unbalanced, vent-to-open logic valves are 2-way switching elements that are spring-biased closed and incorporate an integral shuttle so that the higher of pressures at either port 1 or port 2 can be used as a pilot source. With port 3 blocked, the valve is held in the closed position by the spring force. With port 3 vented, the valve will open provided there is sufficient pressure to overcome the spring force. The force generated at port 3, plus the spring force, must be greater than the sum of the forces acting at port 1 and port 2 for the valve to remain closed. NOTE: The pilot area (port 3) is 1.8 times the area at port 1 and 2.25 times the area at port 2.

TECHNICAL DATA NOTE: DATA MAY VARY BY CONFIGURATION. SEE CONFIGURATION SECTION.

| | |
|---|---------------------------|
| Cavity | T-17A |
| Series | 3 |
| Capacity | 100 gpm |
| Maximum Operating Pressure | 5000 psi |
| Area Ratio, A3 to A1 | 1.8:1 |
| Area Ratio, A3 to A2 | 2.25:1 |
| Control Orifice Diameter | .031 in. |
| Maximum Valve Leakage at 110 SUS (24 cSt) | 10 drops/min. |
| Pilot Volume Displacement | .25 in ³ |
| Valve Hex Size | 1 1/4 in. |
| Valve Installation Torque | 150 - 160 lbf ft |
| Model Weight | 1.10 lb |
| Seal kit - Cartridge | Buna: 990-017-007 |
| Seal kit - Cartridge | Polyurethane: 990-017-002 |
| Seal kit - Cartridge | Viton: 990-017-006 |

OPTION SELECTION EXAMPLE: LOHDXN

| CONTROL | (X) CRACKING PRESSURE | (D) SEAL MATERIAL | (N) MATERIAL/COATING |
|------------------|-----------------------|-------------------------------|--|
| X Not Adjustable | D 50 psi (3,5 bar) | N Buna-N E EPDM V Viton | Standard Material/Coating /AP Stainless Steel, Passivated |

TECHNICAL FEATURES

- These valves have positive seals between port 2 and the pilot area.
- These valves open quickly when vented. Time to close is difficult to predict as it is dependent on the rate of flow and the pressure drop created as it closes.
- Controlling 2 or more of these valves with 1 pilot control is not advised. The shuttle valve creates a flow path between the multiple elements. Using a blocking check on the pilot of each logic valve will prevent this.
- Because these valves are unbalanced, operation is pressure dependent. Opening and closing of the poppet are functions of the force balances on three areas: Port 1 = 100%, Port 2 = 80%, and the Pilot Area = 180%.
- These valves are pressure responsive at all ports, therefore it is essential to consider all aspects of system operation through a complete cycle. Pressure changes at any one port may cause a valve to switch from a closed to an open position, or vice versa. All possible pressure changes in the complete circuit must be considered to assure a safe, functional system design.
- All ports will accept 5000 psi (350 bar).
- Corrosion resistant cartridge valves are intended for use in corrosive environments and are identified by the model code suffix /AP for external stainless steel components, or /LH for external zinc-nickel plated components. See the CONFIGURATION section for all options. For further details, please see the Materials of Construction page located under TECH RESOURCES.
- Incorporates the Sun floating style construction to minimize the possibility of internal parts binding due to excessive installation torque and/or cavity/cartridge machining variations.

PERFORMANCE CURVES

