



MODEL  
**LOHOZ**

Pilot-to-close, spring-biased open, unbalanced poppet logic element with position switch

**CAPACITY: 100 gpm / CAVITY: T-17A**



[sunhydraulics.com/model/LOHOZ](https://sunhydraulics.com/model/LOHOZ)

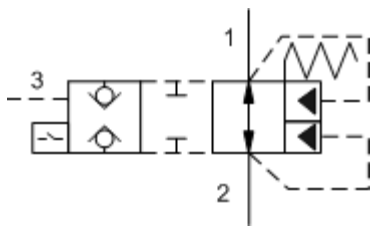

## CONFIGURATION

Cracking Pressure  
Seal Material

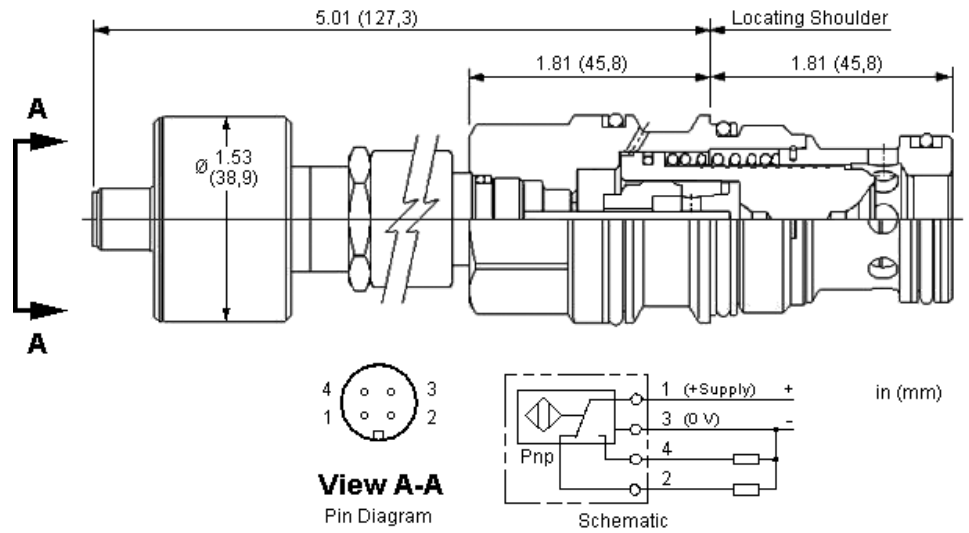

These unbalanced, pilot-to-close logic valves are 2-way switching elements that are spring biased open. Pressure at either work port 1 or 2 will tend to keep the valve open while pressure at port 3 will tend to close it. The force generated at port 3 must be greater than the sum of the forces acting at port 1 and port 2 plus the spring force for the valve to close. NOTE: The pilot area (port 3) is 1.8 times the area at port 1 and 2.25 times the area at port 2. This valve incorporates a position switch to provide confirmation that the valve is spring biased to the fully open position.

## SWITCH SPECIFICATIONS

Supply Voltage	20-30 VDC
Operating Temperature Range	-25 to 80 °C
Vibration	≥ 50g, 0-500 impulses/sec
Shock	>50 g, 1ms
Reverse Polarity Protection	Yes
Maximum Output Load	≤ 400 mA, Duty Ratio 100%
Short Circuit Protection	Yes, Load Short Unlimited
Turn On Time	≤ 25 ms
Hysteresis	≤ .002 in.
Thermal Shift - 0 to 80 °C ±	.004 in.
EMC	DIN EN 61000-6-1/2/3/4
Connector	M12 X 1 (4) Pin
Connector Environment Rating	IP65

## TECHNICAL DATA

NOTE: DATA MAY VARY BY CONFIGURATION. SEE CONFIGURATION SECTION.

Cavity	T-17A
Series	3
Capacity	100 gpm
Maximum Operating Pressure	5000 psi
Area Ratio, A3 to A1	1.8:1
Area Ratio, A3 to A2	2.25:1
Maximum Valve Leakage at 110 SUS (24 cSt)	1 drops/min.
Pilot Passage into Valve	.06 in.
Pilot Volume Displacement	.25 in <sup>3</sup>
Valve Hex Size	1 1/4 in.

Valve Installation Torque	150 - 160 lbf ft
Seal kit - Cartridge	Buna: 990-017-007
Seal kit - Cartridge	Polyurethane: 990-017-002
Seal kit - Cartridge	Viton: 990-117-006

## OPTION SELECTION EXAMPLE: LOHOZN

CRACKING PRESSURE

(D) SEAL MATERIAL

(V)

D 50 psi (3,5 bar)

V Viton

N Buna-N

### TECHNICAL FEATURES

- These valves have positive seals between port 2 and the pilot area.
- This cartridge is supplied as a sealed, factory set unit and is not field serviceable. Any tampering will violate the product warranty.
- When torquing this cartridge into its cavity, a crow's foot wrench or similar will be required since the position switch precludes the use of a deep socket wrench.
- Because these valves are unbalanced, operation is pressure dependent. Opening and closing of the poppet are functions of the force balances on three areas: Port 1 = 100%, Port 2 = 80%, and the Pilot Area = 180%.
- These valves are pressure responsive at all ports, therefore it is essential to consider all aspects of system operation through a complete cycle. Pressure changes at any one port may cause a valve to switch from a closed to an open position, or vice versa. All possible pressure changes in the complete circuit must be considered to assure a safe, functional system design.
- All ports will accept 5000 psi (350 bar).
- Position switch is CE approved.
- An optional protective cover, with mounting hardware included, may be ordered separately. See kit number: 991-043.
- Incorporates the Sun floating style construction to minimize the possibility of internal parts binding due to excessive installation torque and/or cavity/cartridge machining variations.

### PERFORMANCE CURVES

