

CONFIGURATION

X _____

 Material/Coating _____

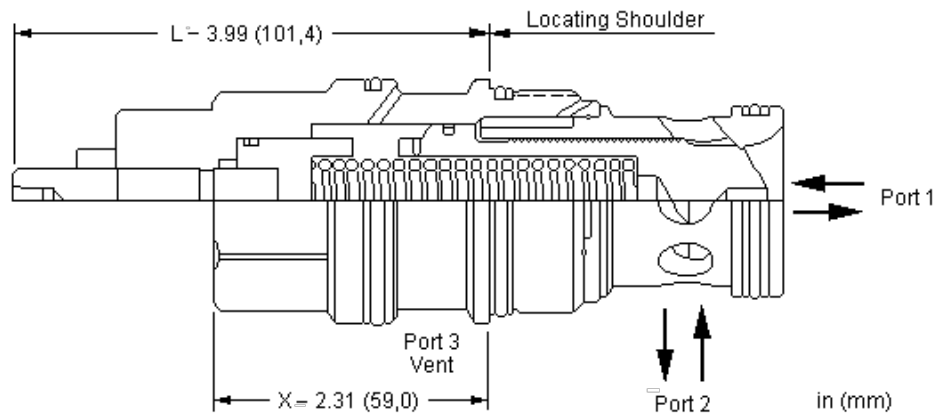

2 1 3 1 2 2 1

TECHNICAL DATA NOTE: DATA MAY VARY BY CONFIGURATION. SEE CONFIGURATION SECTION.

	T-19AU
	4
	1100 L/min.
	350 bar
	7,7 cc
110 SUS (24 cSt)	0,7 cc/min.
A3 A1	1.8:1
A3 A2	2.25:1
	0,9 mm
	41,3 mm
	474 - 508 Nm
	1,20 kg
Seal kit - Cartridge	Buna: 990-019-007
Seal kit - Cartridge	Polyurethane: 990-019-002
Seal kit - Cartridge	Viton: 990-019-006

OPTION SELECTION EXAMPLE: LOKAXN

	(X)	(D)	(V)	MATERIAL/COATING
X	D 50 psi (3,5 bar)	V	Standard Material/Coating	
L		N	/AP	

TECHNICAL FEATURES

- Sun T-19A T-19AU
- 2
-
- 1 =100% 2 =80% =180%
-
- 5000 psi (350 bar)
- /AP
- Sun /

316

PERFORMANCE CURVES

