

CONFIGURATION

X	
H	200 psi (14 bar)
N	
Material/Coating	

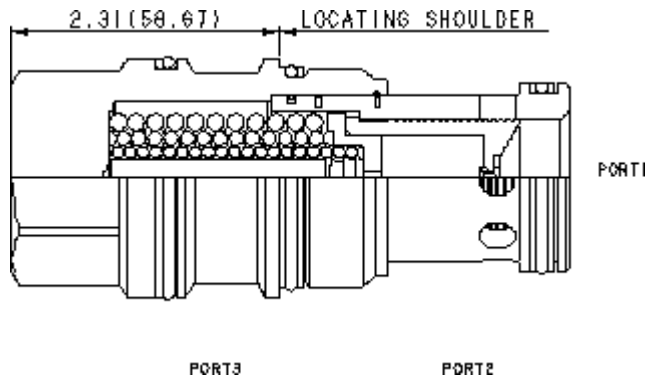

TECHNICAL DATA NOTE: DATA MAY VARY BY CONFIGURATION. SEE CONFIGURATION SECTION.

	T-19A
	4
	480 L/min.
	350 bar
	41,3 mm
	474 - 508 Nm
Seal kit - Cartridge	Buna: 990-019-007
Seal kit - Cartridge	EPDM: 990-019-014
Seal kit - Cartridge	Polyurethane: 990-019-002
Seal kit - Cartridge	Viton: 990-019-006
Seal kit - Cartridge	Buna: 990-019-007
Seal kit - Cartridge	EPDM: 990-019-014
Seal kit - Cartridge	Polyurethane: 990-019-002
Seal kit - Cartridge	Viton: 990-019-006

OPTION SELECTION EXAMPLE: LRJCXHN

	(X)	(H)	(N)	MATERIAL/COATING
X	H	200 psi (14 bar)	N	Standard Material/Coating
L	D	50 psi (3,5 bar)	E	EPDM
	F	100 psi (7 bar)	V	/AP
	G	150 psi (10,5 bar)		

TECHNICAL FEATURES

- EPDM
- L
- 5000 psi (350 bar)
- /AP
- Sun /

316