

3-Port Non-vented, Fixed Setting

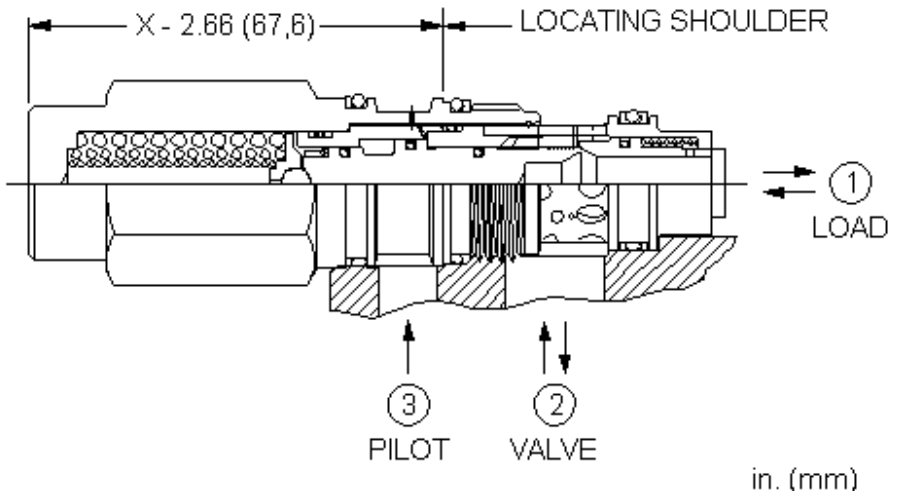

CONFIGURATION

- L** Factory Set 4000 psi (280 bar)
- N** Seal Material Buna-N

Fixed setting, load reactive, load control valves with pilot assist combine two valves; a check valve and a relief valve. The check valve allows free flow from the directional valve (port 2) to the load (port 1) while a direct-acting, pilot-assisted relief valve controls flow from port 1 to port 2. Pilot assist at port 3 lowers the effective setting of the relief valve at a rate determined by the pilot ratio.

TECHNICAL DATA

| | |
|--|---------------------------|
| Maximum Operating Pressure | 5000 psi |
| Pilot Ratio | 1.5:1 |
| Maximum Recommended Load Pressure | See Technical Features |
| Check Cracking Pressure | 25 psi |
| Factory Pressure Settings Established at | 2 in ³ /min. |
| Maximum Valve Leakage at Reseat | 5 drops/min. |
| Reseat | ≥77% of setting |
| Seal kit - Cartridge | Buna: 990-202-007 |
| Seal kit - Cartridge | Polyurethane: 990-002-002 |
| Seal kit - Cartridge | Viton: 990-202-006 |

CONFIGURATION OPTIONS

Model Code Example: **MBEBXLN**

FACTORY SET

(L)

SEAL MATERIAL

(N)

- L** 4000 psi (280 bar)
- K** 3000 psi (210 bar)
- M** 5000 psi (350 bar)

- N** Buna-N
- V** Viton