

3-Port Non-vented, Fixed Setting

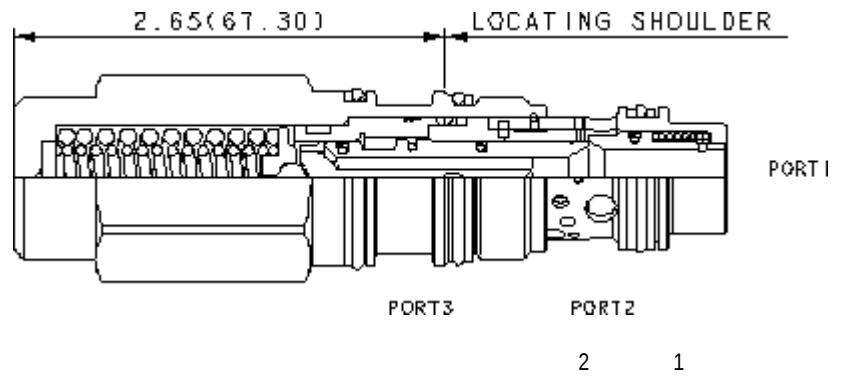

TECHNICAL DATA NOTE: DATA MAY VARY BY CONFIGURATION. SEE CONFIGURATION SECTION.

	T-2A
	2
	120 L/min.
	350 bar
	1.5:1
	See Technical Features
	1,7 bar
	0,3 cc/min.
	30 cc/min.
	≥77% of setting
	28,6 mm
	61 - 68 Nm
Seal kit - Cartridge	Buna: 990-202-007
Seal kit - Cartridge	Polyurethane: 990-002-002
Seal kit - Cartridge	Viton: 990-202-006

OPTION SELECTION EXAMPLE: MBEEXLN

(L)

(N)

L 4000 psi (280 bar)

N

K 3000 psi (210 bar)

V

M 5000 psi (350 bar)

TECHNICAL FEATURES

- K 2300psi 154bar K 3350psi 210bar
- L 3075psi 215bar L 4350psi 300bar
- K 3850psi 270bar M 5350psi 370bar
-
-
- ±50psi 3.5bar ±350psi(20bar)
- 2 , 1+ x
- 3
-
- 3
-
- Sun
-
-
- Sun

PERFORMANCE CURVES

