

3-Port Non-vented, Fixed Setting

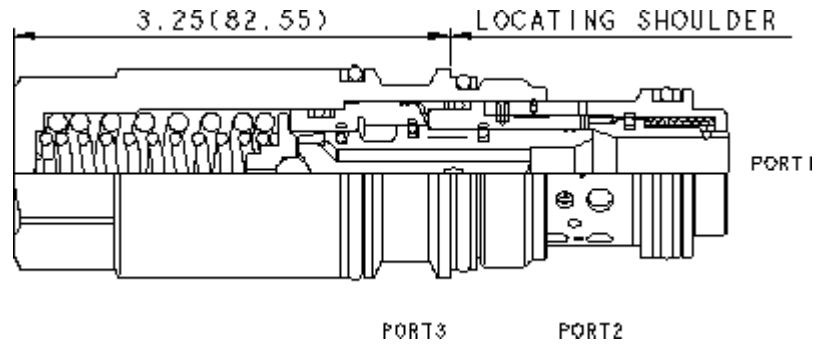

TECHNICAL DATA NOTE: DATA MAY VARY BY CONFIGURATION. SEE CONFIGURATION SECTION.

cavidad	T-17A
Series	3
Capacity	240 L/min.
Maximum Operating Pressure	350 bar
Pilot Ratio	3:1
Maximum Recommended Load Pressure	See Technical Features
Check Cracking Pressure	1,7 bar
Factory Pressure Settings Established at	30 cc/min.
Maximum Valve Leakage at Reseat	0,3 cc/min.
Reseat	≥77% of setting
Valve Hex Size	31,8 mm
Valve Installation Torque	203 - 217 Nm
Seal kit - Cartridge	Buna: 990-017-007
Seal kit - Cartridge	EPDM: 990-017-014
Seal kit - Cartridge	Polyurethane: 990-017-002
Seal kit - Cartridge	Viton: 990-017-006

OPTION SELECTION EXAMPLE: MBGAXLN

FACTORY SET

- L** 4000 psi (280 bar)
- K** 3000 psi (210 bar)
- M** 5000 psi (350 bar)

(L) SEAL MATERIAL

- N** Buna-N
- E** EPDM
- V** Viton

(N) MATERIAL/COATING

- Standard Material/Coating**
- /LH** Mild Steel, Zinc-Nickel

PERFORMANCE CURVES

