

**CONFIGURATION**

L	
A	500 - 3000 psi (35 - 210 bar), 1000 psi (70 bar)
N	
Material/Coating	

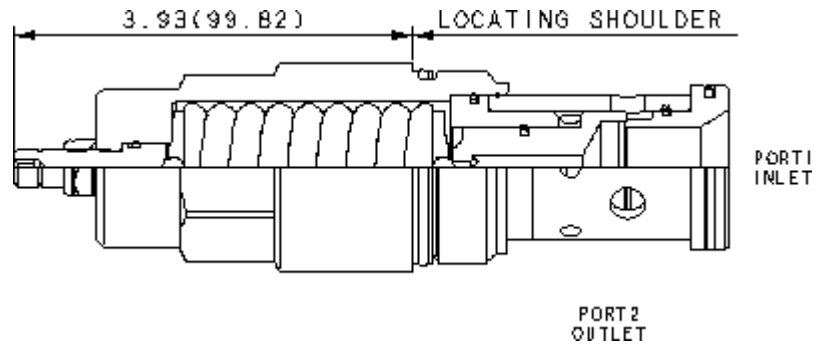

**TECHNICAL DATA** NOTE: DATA MAY VARY BY CONFIGURATION. SEE CONFIGURATION SECTION.

	T-18A
	4
	760 L/min.
	350 bar
	0,7 cc/min.
	15 L/min.
	2 ms
	>90% of setting
-	6
	41,3 mm
	474 - 508 Nm
	4 mm
	15 mm
	9 - 10 Nm
	1.50 kg.
Seal kit - Cartridge	Buna: 990-318-007
Seal kit - Cartridge	EPDM: 990-318-014
Seal kit - Cartridge	Viton: 990-318-006
Seal kit - Cartridge	Buna: 990-318-007
Seal kit - Cartridge	EPDM: 990-318-014
Seal kit - Cartridge	Viton: 990-318-006

## OPTION SELECTION EXAMPLE: RDJALAN

	(L)	(A)	(N)	MATERIAL/COATING	(/LH)
<b>L</b>	<b>A</b>	500 - 3000 psi (35 - 210 bar), 1000 psi (70 bar)	<b>N</b>	/LH	-
	<b>B</b>	300 - 1500 psi (20 - 105 bar), 1000 psi (70 bar)	<b>E</b>	EPDM	
	<b>C</b>	1000 - 6000 psi (70 - 420 bar), 1000 psi (70 bar)	<b>V</b>		Standard Material/Coating
	<b>D</b>	200 - 800 psi (14 - 55 bar), 400 psi (28 bar)			
	<b>E</b>	100 - 400 psi (7 - 28 bar), 200 psi (14 bar)			
	<b>S</b>	50 - 200 psi (3,5 - 14 bar), 100 psi (7 bar)			
	<b>W</b>	800 - 4500 psi (55 - 315 bar), 1000 psi (70 bar)			

### TECHNICAL FEATURES

- 2
- 2
- 
- 
- 
- 
- 
- 2                    1:1
- EPDM
- Sun                    /
- : A    - 2000 psi (138 bar), B    - 1000 psi (69 bar), C    - 4000 psi (276 bar), D    - 800 psi (55 bar), E    - 400 psi (28 bar), S    - 1000 psi (70 bar), W    - 3000 psi (207 bar)
- 90%

### PERFORMANCE CURVES

