

Meter In P Normally Closed

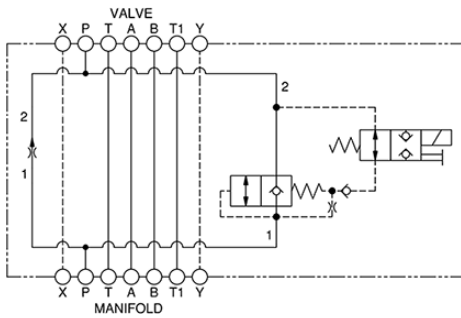

Meter In P Normally Open

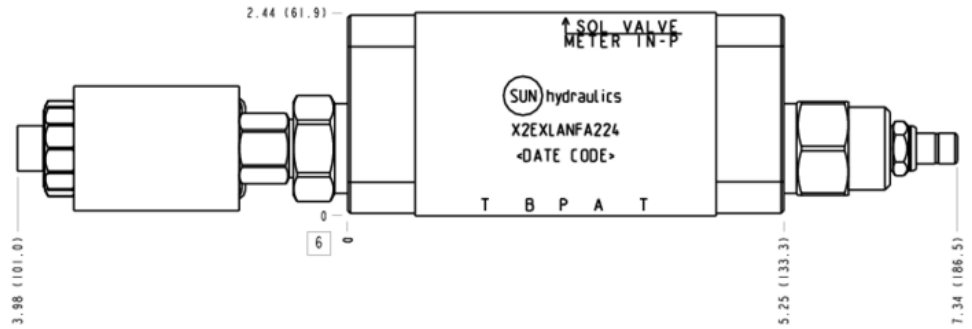

This assembly consists of a fixed-orifice, pressure-compensated flow control valve which provides precise flow regulation for meter-in or meter-out applications where there may be wide pressure fluctuations. The flow setting is specified by the user and is set at the factory. The rapid or feed rate is selected by a solenoid operated (normally open or closed) 2-way, 2-position valve.

**TECHNICAL DATA** NOTE: DATA MAY VARY BY CONFIGURATION. SEE CONFIGURATION SECTION.

Body Type	Sandwich
Interface	ISO 05 - X&Y
Capacity	30 gpm
Body Features	Meter in P
Control Flow Range	0 - 12 gpm
Seal Plate Included (see notes)	No
Stack Height	2.49 in.

- NOTES:**
- Stack height value in technical data table includes seal retainer plate.
  - This installation requires a seal retainer plate and seal kit which are purchased separately. See "Related Accessories" section.
  - For detailed information regarding the cartridges contained in this assembly, click on the models codes shown in the Included Components tab.
  - Important:** Carefully consider the maximum system pressure. The pressure rating of the manifold is dependent on the manifold material, with the port type/size a secondary consideration. Manifolds constructed of aluminum are not rated for pressures higher than 3000 psi (210 bar), regardless of the port type/size specified.

**OPTION SELECTION EXAMPLE: X2EXLANFA224**

CONTROL	(L) SETTING RANGE	(A) SEAL MATERIAL	(N)
<b>L</b> Tuning Adjustment	<b>A</b> Replaceable Orifice .1 - 12 gpm (0,4 - 45 L/min.)	<b>N</b> Buna-N	
X Not Adjustable	<b>B</b> Permanent Orifice .1 - 12 gpm (0,4 - 45 L/min.)	<b>V</b> Viton	
	<b>I</b> Incomplete (no orifice) 17 gpm (64 L/min.)		

**INCLUDED COMPONENTS**

Part	Description	Quantity
DFDA8DN	Cartridge	1
DTAFMHN224	Cartridge	1
FXDALAN	Cartridge - Primary	1

**TECHNICAL FEATURES**

- The sharp-edged orifice design minimizes flow variations due to viscosity changes.
- The tuneable control option provides +/- 25% variation from the nominal factory pre-set flow. Turn the adjustment clockwise to increase.
- Customer must specify a flow rating. Factory set flow ratings are within +/- 10% of the requested setting.
- Now available with FLeX Series solenoid valves. See CONFIGURATION section, SOLENOID DESIGNATION to specify.

**MANIFOLD FACES**

**FACE GRID**

1	2	3	4
5	6	7	8
9	10	11	12

FACE 2

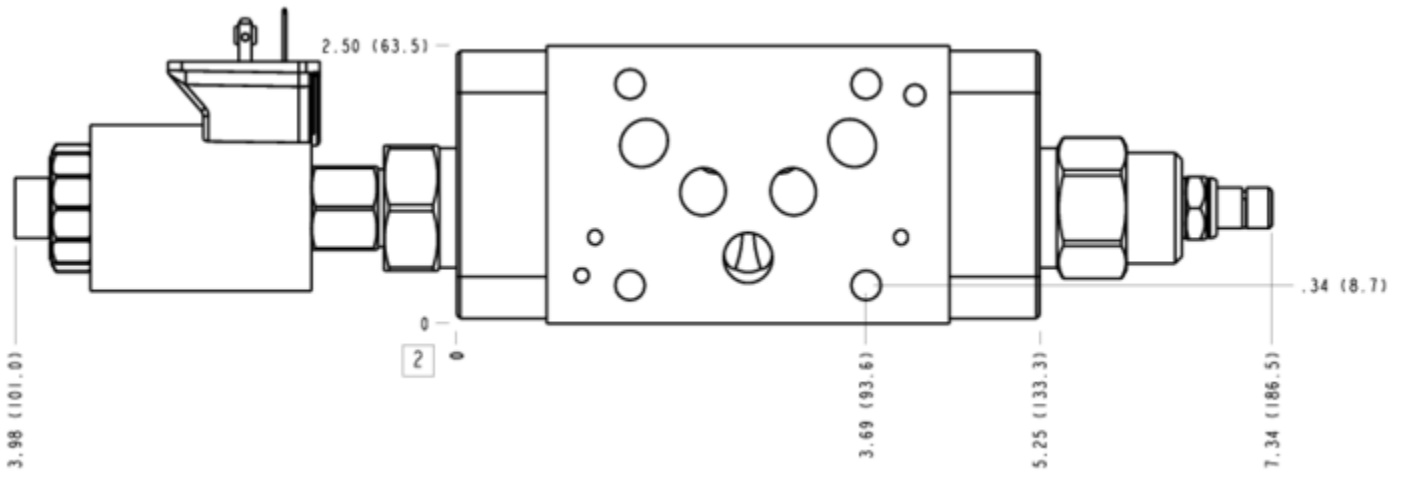

FACE 5

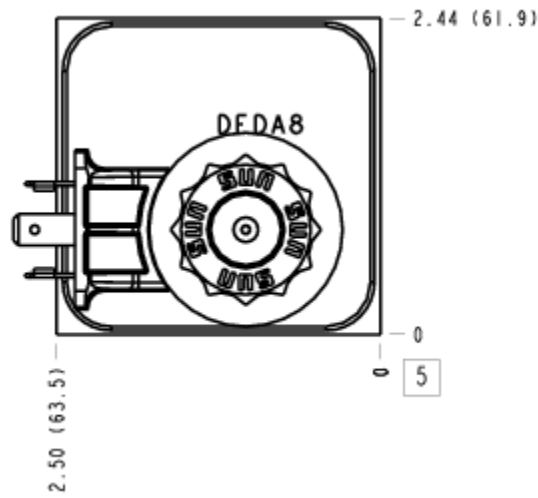

FACE 6

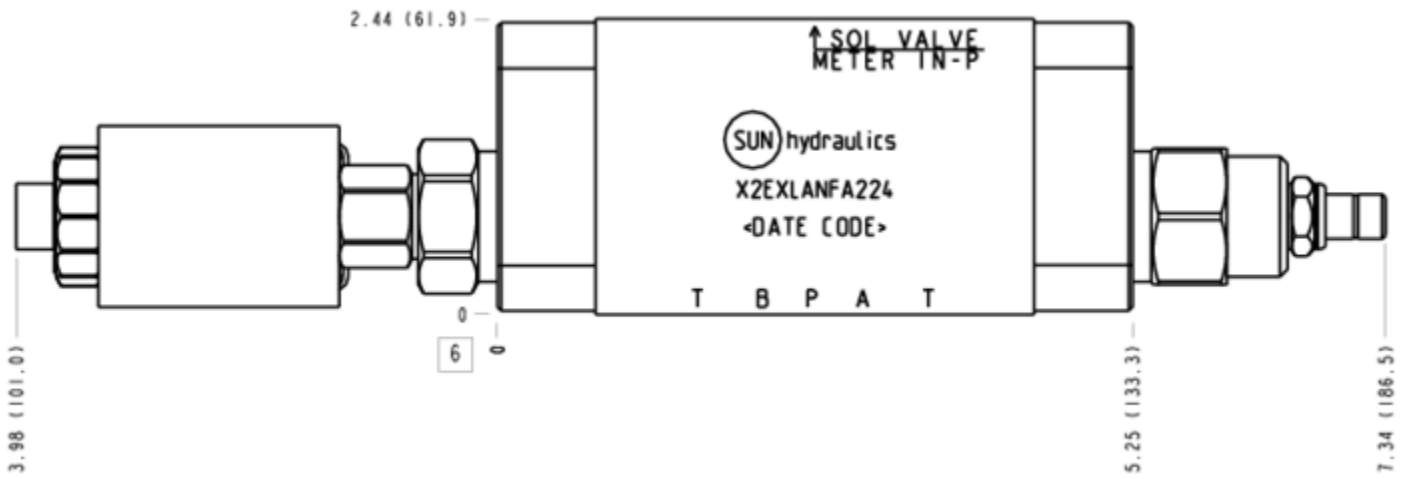

### FACE 7

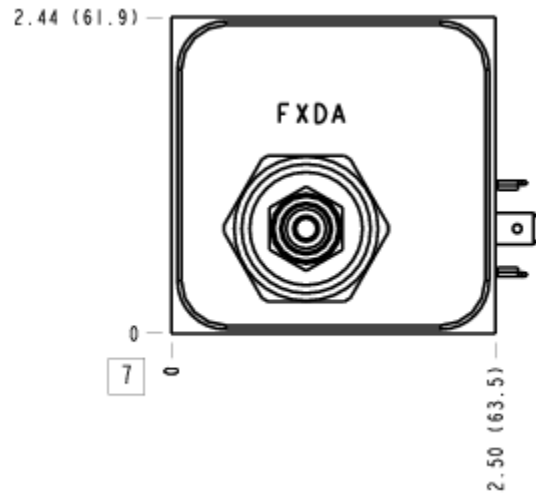

### FACE 8

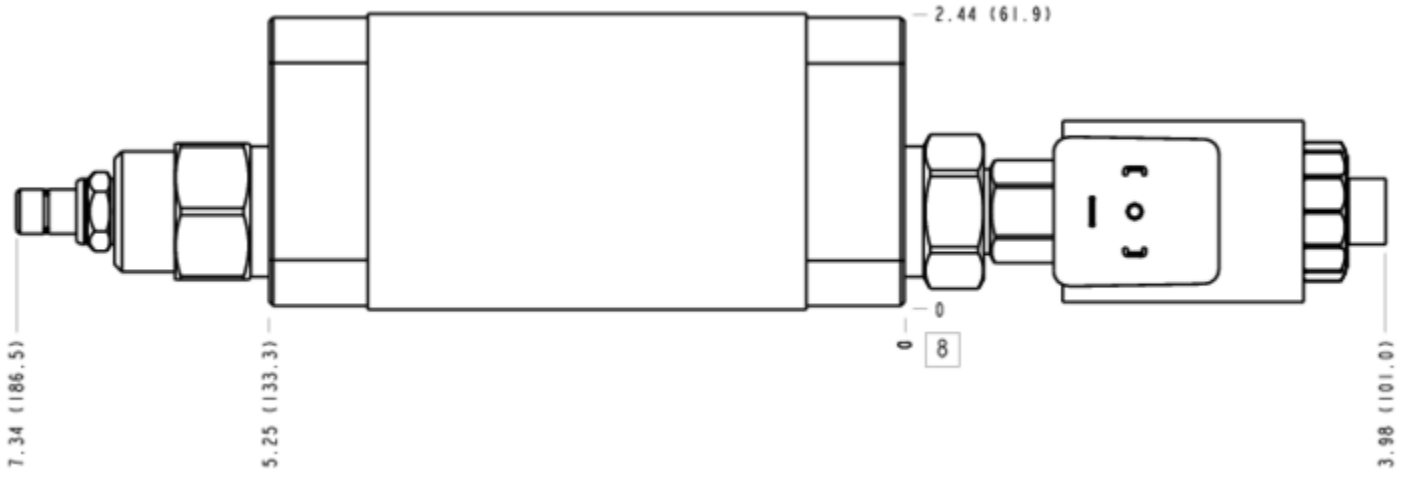

### FACE 10

