

METER OUT T NORMALLY CLOSED

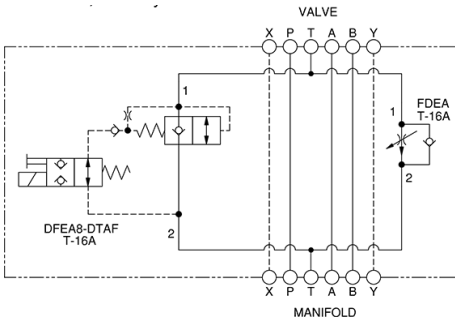

Meter Out T Normally Open

TECHNICAL DATA NOTE: DATA MAY VARY BY CONFIGURATION. SEE CONFIGURATION SECTION.

Body Type	aplillables
Interface	ISO 07
Capacity	240 L/min.
Body Features	descarga regulada en T
Control Flow Range	0 - 25 gpm
Seal Plate Included (see notes)	Yes
Stack Height	90 mm

OPTION SELECTION EXAMPLE: X3FDLANFA

CONTROL		(L) ADJUSTMENT RANGE	(A) SEAL MATERIAL	(N)	
L	Standard Screw Adjustment	A	.2 - 25 gpm (0,8 - 95 L/min.)	N	Buna-N
H	Calibrated Handknob with Detent Lock	B	.2 - 16 gpm (0,8 - 60 L/min.)	V	Viton
K	manilla				

INCLUDED COMPONENTS

Part	Description	Quantity
500-001-111*	O-Ring	2
500-001-118*	O-Ring	4
700-006*	Seal Plate	1
811-001-006*	Pin	2
DFA8DN	Cartridge	1
DTAFMHN	Cartridge	1
FDEALAN	Cartridge - Primary	1