

Meter in A Normally Open

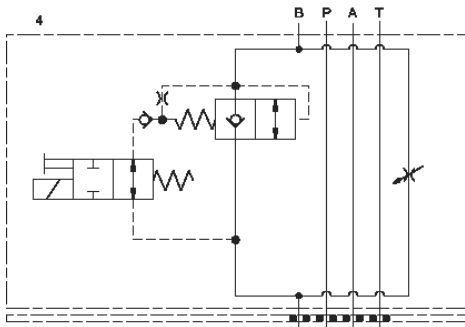

Meter in B Normally Open

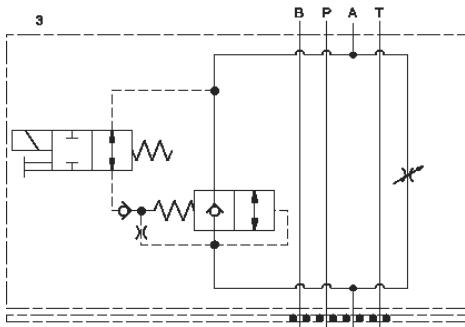

Meter out A Normally Open

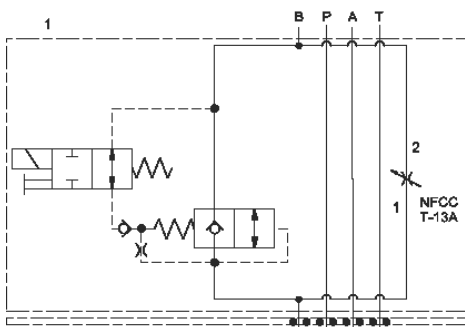

Meter out B Normally Open

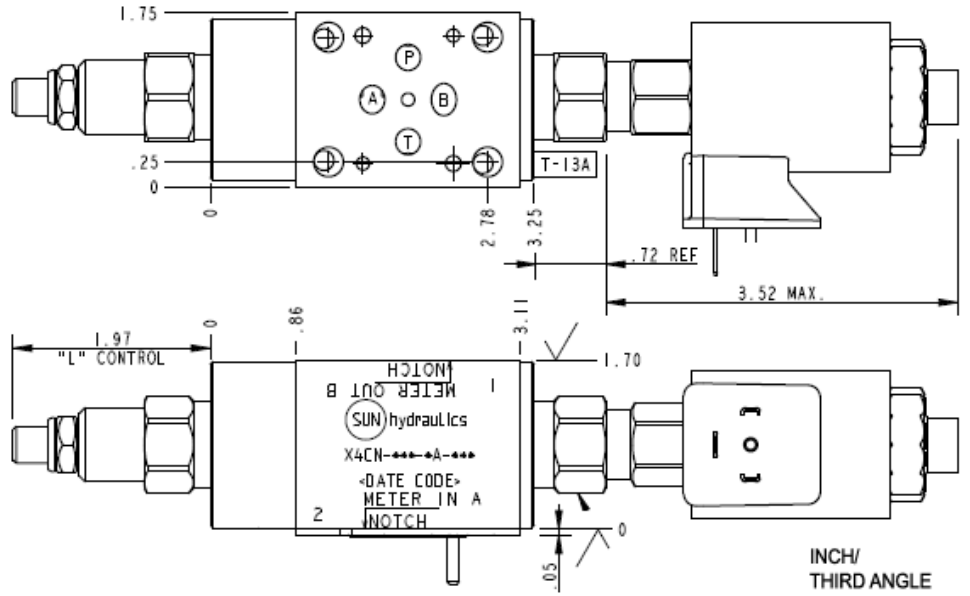

TECHNICAL DATA NOTE: DATA MAY VARY BY CONFIGURATION. SEE CONFIGURATION SECTION.

Body Type	apilables
Interface	ISO 03
Body Features	alimentación regulada en A o B, descarga regulada en A o B
Control Flow Range	0 - 7 gpm
Seal Plate Included (see notes)	Yes
Stack Height	44,5 mm

CONFIGURATION OPTIONS

Model Code Example: X4CNLCNFA224

CONTROL	(L) MAXIMUM ORIFICE DIAMETER	(C) SEAL MATERIAL	(N)
L Standard Screw Adjustment	C .19 in. (4,8 mm)	N Buna-N	
H Calibrated Handknob with Detent Lock	D .09 in. (2,3 mm)	V Viton	
K manilla			

INCLUDED COMPONENTS

Part	Description	Quantity
500-001-012*	O-Ring	4
700-002*	Seal Plate	1
811-001-006*	Pin	1
DFCA8DN	Cartridge	1
DTAFMHN224	Cartridge	1
NFCCLCN	Cartridge - Primary	1