

Meter in on A

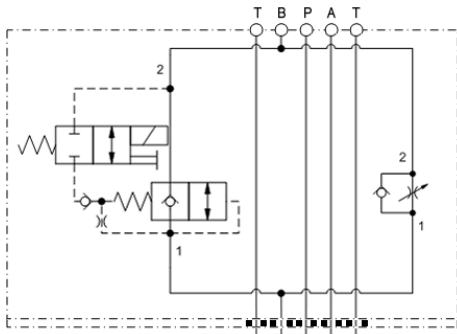

Meter out on B

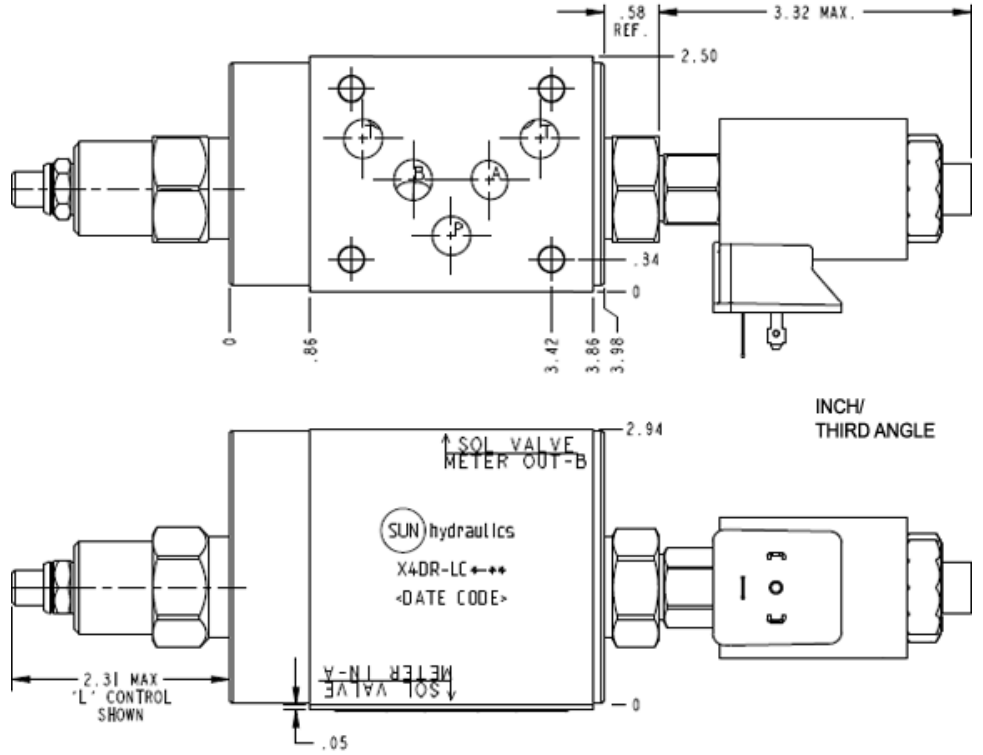

TECHNICAL DATA NOTE: DATA MAY VARY BY CONFIGURATION. SEE CONFIGURATION SECTION.

Body Type	apilables
Interface	ISO 05
Body Features	Meter in on A or meter out on B
Control Flow Range	0 - 12 gpm
Seal Plate Included (see notes)	Yes
Stack Height	87 mm

CONFIGURATION OPTIONS

Model Code Example: X4DRLCNFA224

CONTROL	(L) ANTI-RETORNO DE CAUDAL INVERSO	(C) SEAL MATERIAL	(N)
L Standard Screw Adjustment	C 30 psi (2 bar)	N Buna-N	
H Calibrated Handknob with Detent Lock		V Viton	
K manilla			

INCLUDED COMPONENTS

Part	Description	Quantity
500-001-014*	O-Ring	5
700-001*	Seal Plate	1
DFDA8DN	Cartridge	1
DTAFMHN224	Cartridge	1
NCEBLCN	Cartridge - Primary	1