

Meter Out B Normally Open

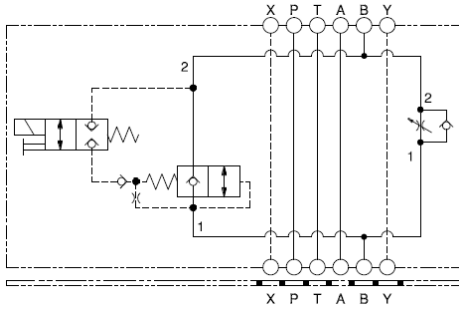

Meter Out B Normally Closed

TECHNICAL DATA NOTE: DATA MAY VARY BY CONFIGURATION. SEE CONFIGURATION SECTION.

Body Type	aplilables
Interface	ISO 07
Body Features	descarga regulada en B
Control Flow Range	0 - 30 gpm
Seal Plate Included (see notes)	Yes
Stack Height	90 mm

CONFIGURATION OPTIONS

Model Code Example: X7FRLCNFA

CONTROL	(L) ANTI-RETORNO DE CAUDAL INVERSO	(C) SEAL MATERIAL	(N)
L Standard Screw Adjustment	C 30 psi (2 bar)	N Buna-N	
H Calibrated Handknob with Detent Lock		V Viton	
K manilla			

INCLUDED COMPONENTS

Part	Description	Quantity
500-001-111*	O-Ring	2
500-001-118*	O-Ring	4
700-006*	Seal Plate	1
811-001-006*	Pin	2
DFEA8DN	Cartridge	1
DTAFMHN	Cartridge	1
NCFBLCN	Cartridge - Primary	1