

A - Normally Open 1 to 2

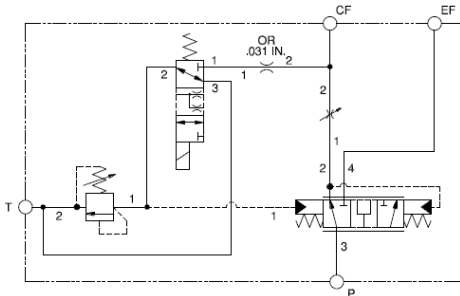

N - Normally Open 2 to 3

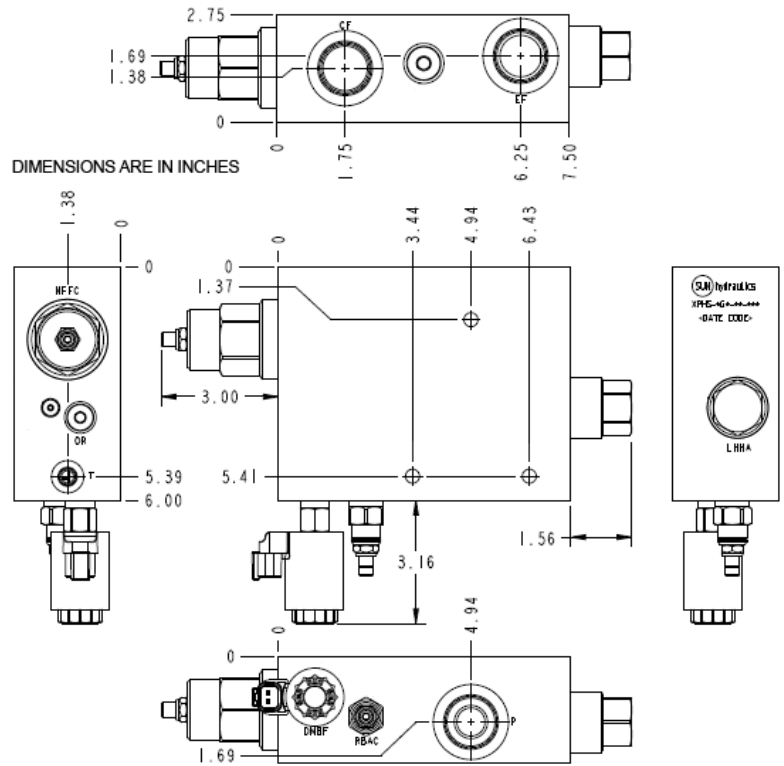

TECHNICAL DATA NOTE: DATA MAY VARY BY CONFIGURATION. SEE CONFIGURATION SECTION.

Body Type	montaje en línea
Mounting Hole Diameter	9,1 mm
Mounting Hole Depth	Through
Mounting Hole Quantity	3

CONFIGURATION OPTIONS

Model Code Example: XPHSLGNNM

CONTROL	(L) MAXIMUM ORIFICE DIAMETER	(G) SEAL MATERIAL	(N)
L Standard Screw Adjustment	G .56 in. (14,2 mm)	N Buna-N	
K manilla		V Viton	

INCLUDED COMPONENTS

Part	Description	Quantity
280-039-031*	Orifice	1
A330-006-002*	SAE Plug	1
A330-006-006*	SAE Plug	1
A330-006-010*	SAE Plug	1
DMBFXNN	Cartridge	1
LHHAXFN	Cartridge	1
NFFCLGN	Cartridge - Primary	1
RBACLAN	Cartridge	1