

A - Normally Open 1 to 2

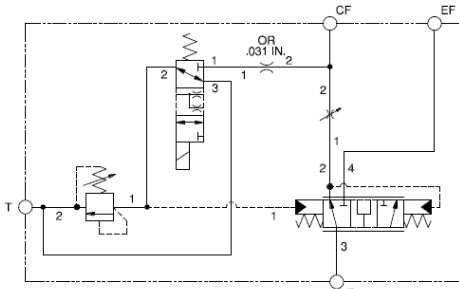

N - Normally Open 2 to 3

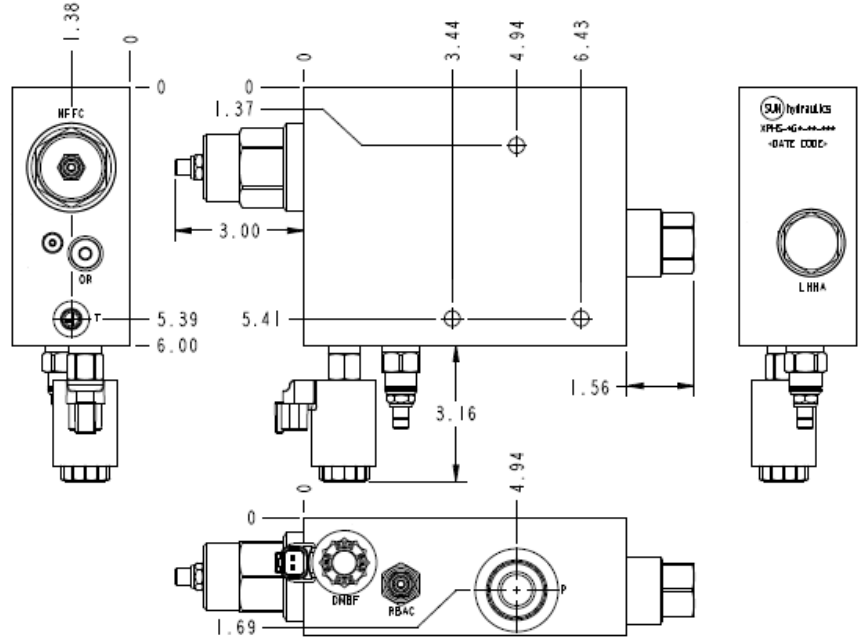
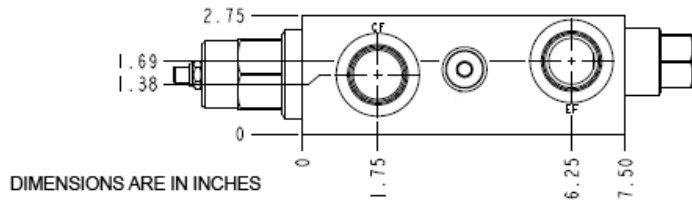

TECHNICAL DATA

Body Type	Line mount
Capacity	240 L/min.
Mounting Hole Diameter	9,1 mm
Mounting Hole Depth	Through
Mounting Hole Quantity	3

OPTION SELECTION EXAMPLE: XPHSLGNNM

CONTROL	(L) MAXIMUM ORIFICE DIAMETER	(G) SEAL MATERIAL	(N)
L Standard Screw Adjustment	G .56 in. (14.2 mm)	N Buna-N	
		V Viton	

INCLUDED COMPONENTS

Part	Description	Quantity
280-039-031*	Orifice	1
A330-006-002*	SAE Plug	1
A330-006-006*	SAE Plug	1
A330-006-010*	SAE Plug	1
DMBFXNN	Cartridge	1
LHHAXFN	Cartridge	1
NFFCLGN	Cartridge - Primary	1
RBACLAN	Cartridge	1

MANIFOLD FACES

FACE GRID

1	2	3	4
5	6	7	8
9	10	11	12

FACE 2

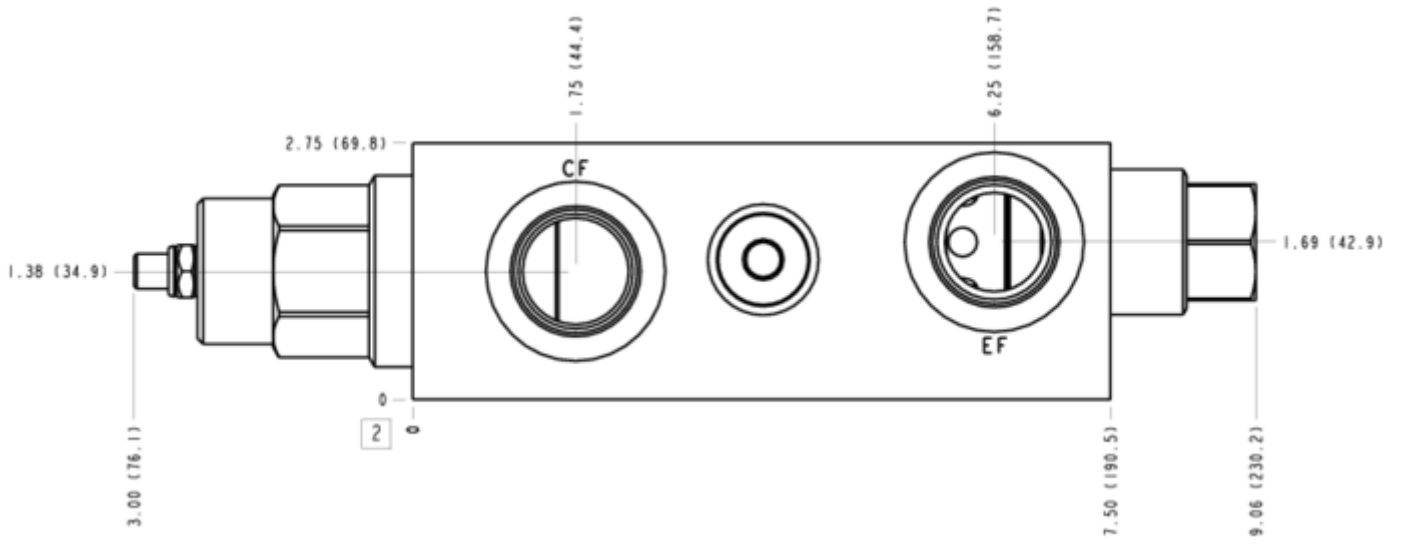

FACE 5

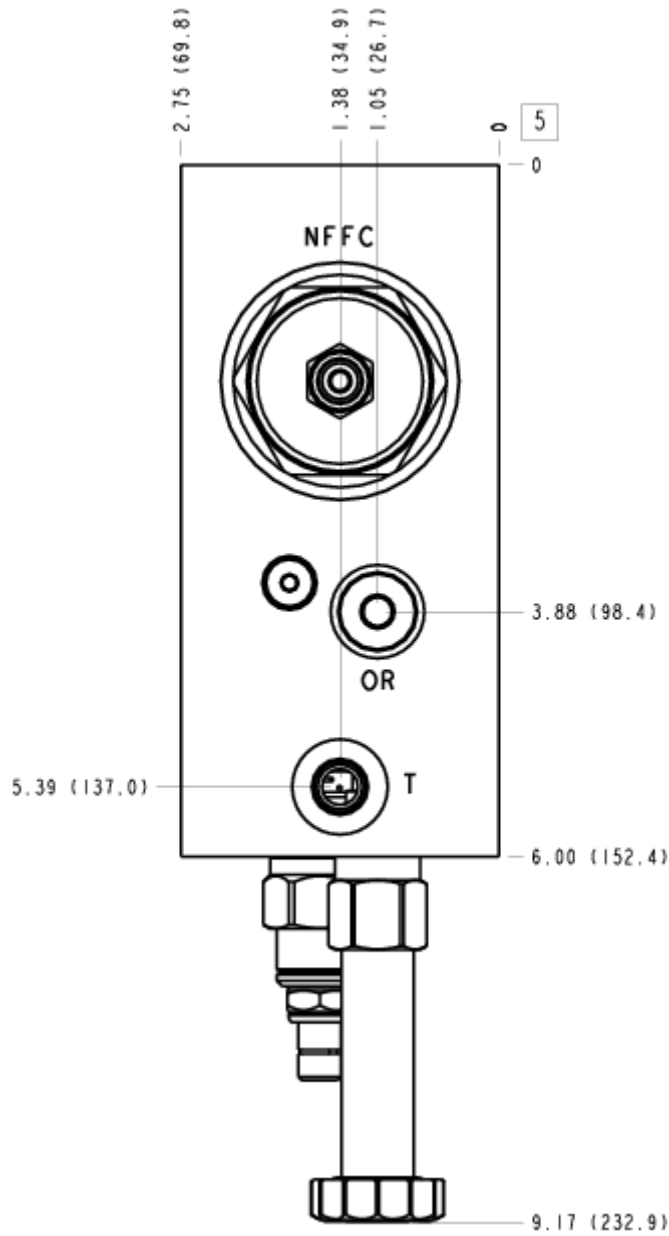

FACE 6

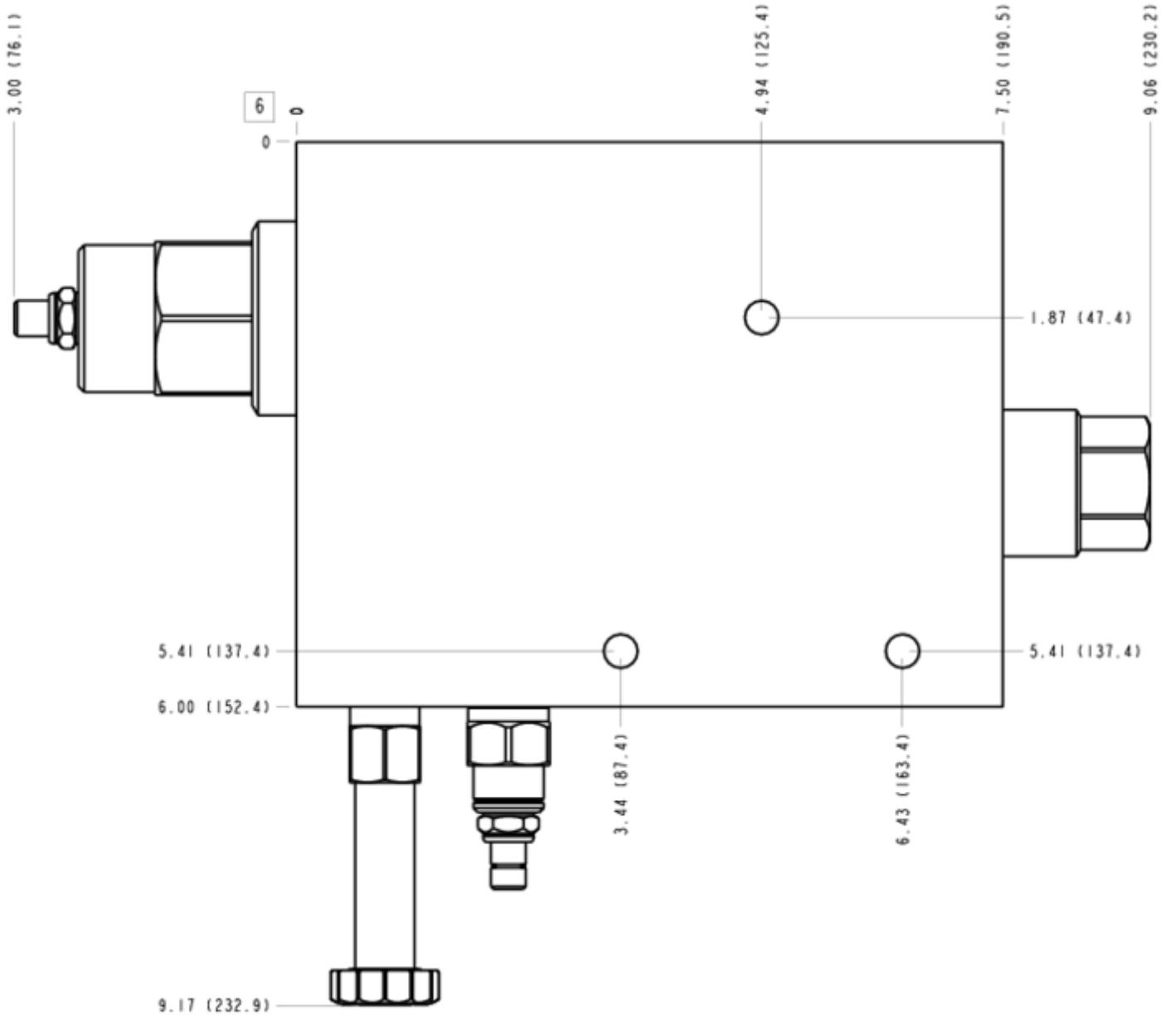

FACE 7

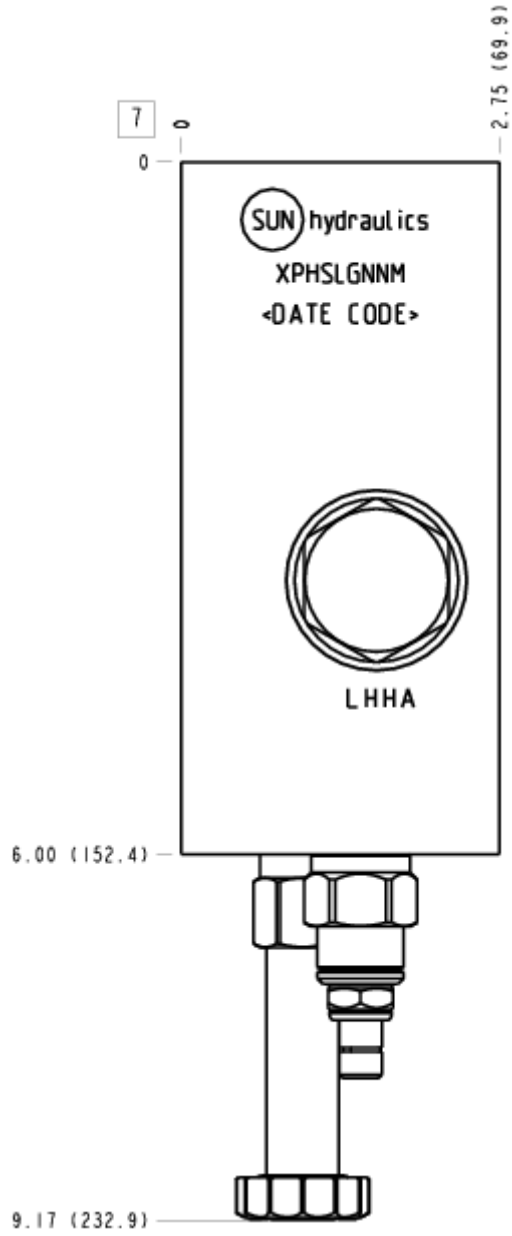

FACE 8

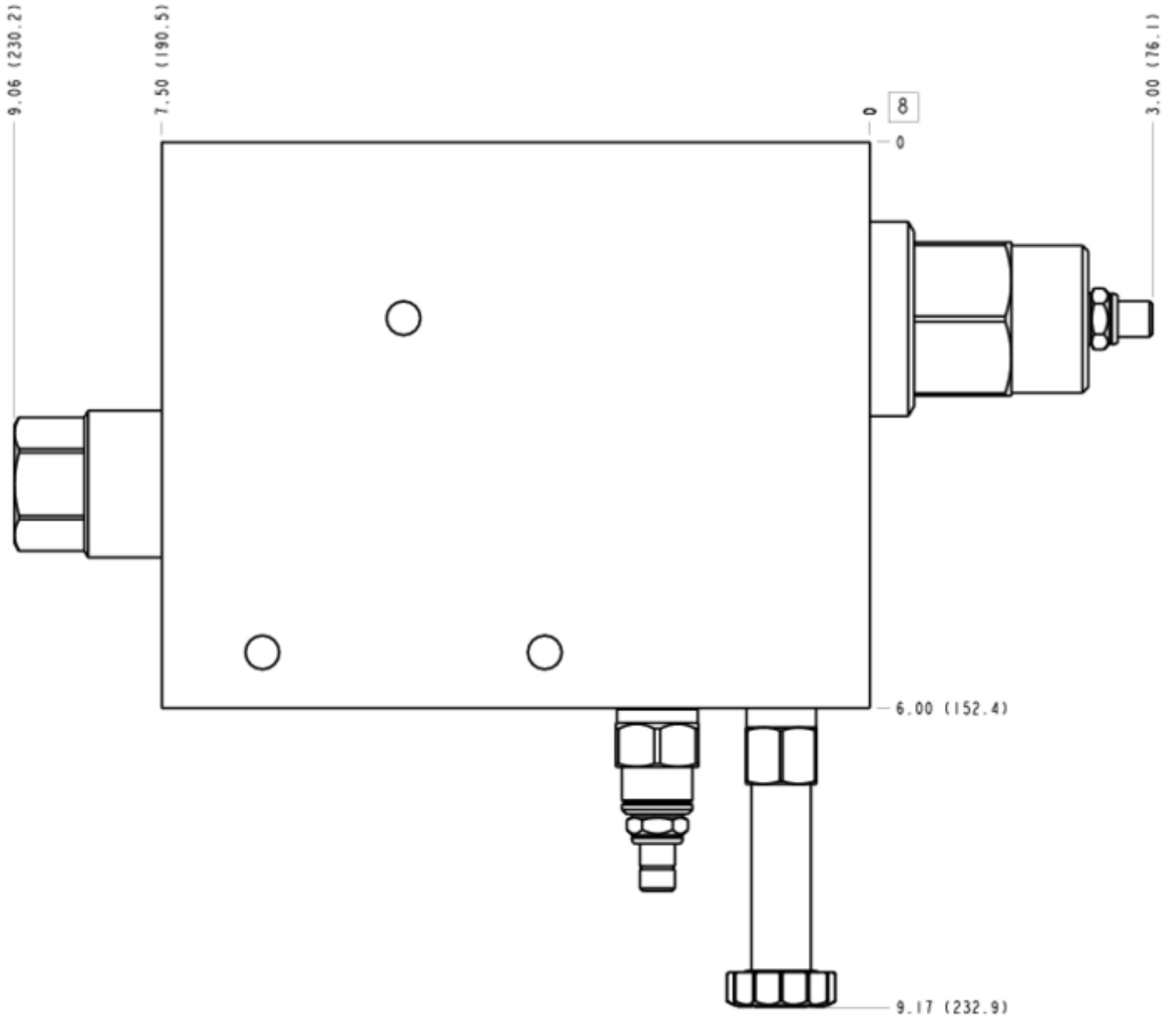

FACE 10

