

This valve assembly is meant to charge an accumulator using a fixed displacement pump. It incorporates a ventable priority flow control valve. When the pressure reaches the set point of the valve, the priority flow control is vented and all of the pump flow is available to the system. When the pressure drops to the value determined by the fixed percentage of the pilot valve, the priority flow is used to recharge the accumulator. Only the priority flow is directed to the accumulator leaving the rest of the pump flow available to the system. The assembly has two additional features; a simple circuit that softens the unloading of the pump and a system over-pressure relief.

TECHNICAL DATA NOTE: DATA MAY VARY BY CONFIGURATION. SEE CONFIGURATION SECTION.

Body Type	Line mount
Capacity	15 gpm
Mounting Hole Quantity	2

- NOTES:**
- **Important:** Carefully consider the maximum system pressure. The pressure rating of the manifold is dependent on the manifold material, with the port type/size a secondary consideration. Manifolds constructed of aluminum are not rated for pressures higher than 3000 psi (210 bar), regardless of the port type/size specified.
 - For detailed information regarding the cartridges contained in this assembly, click on the models codes shown in the Included Components tab.

OPTION SELECTION EXAMPLE: XQCJLANBK

CONTROL	(L) ADJUSTMENT RANGE	(A) SEAL MATERIAL	(N)
L Standard Screw Adjustment	A 1000 - 3000 psi (70 - 210 bar), 1000 psi (70 bar) Standard Setting	N Buna-N	
C Tamper Resistant - Factory Set		V Viton	
K Handknob			

PRIMARY CARTRIDGE (B)

B 20% (with QCDB primary cartridge, 20%, accumulator sense, pump unload valve with check - pilot capacity)
E 10% (with QCDE primary cartridge, 10%, accumulator sense, pump unload valve with check - pilot capacity)
D 50% (with QCDD primary cartridge, 50%, accumulator sense, pump unload valve with check - pilot capacity)
C 30% (with QCDC primary cartridge, 30%, accumulator sense, pump unload valve with check - pilot capacity)
A 15% (with QCDA primary cartridge, 15%, accumulator sense, pump unload valve with check - pilot capacity)

INCLUDED COMPONENTS

Part	Description	Quantity
A330-006-004*	SAE Plug	1
A330-006-006*	SAE Plug	1
A330-006-012*	SAE Plug	1
FVCAXAN	Cartridge	1
LPBDXDN	Cartridge	1
QCDBLAN	Cartridge - Primary	1
RDDFXBN	Cartridge	1

TECHNICAL FEATURES

- When applying this assembly, a separate drain line is required to prevent erratic operation caused by tank line pressure fluctuations.
- NOTE: Careful consideration should be given when selecting an adjustment range. System pressure drops and flows tend to affect the operation of unloading valves. Low operating pressures combined with low differentials result in a very narrow band between unload and reset, requiring precise system design. High flow rates typically mean high pressure drops, which subtract from the differential the valve has to work with.
- The pressure setting and the resultant reseal pressure are in reference to the port 2 area of the QCD* pilot valve. Pump pressure will be higher and accumulator pressure will be lower due to pressure drop caused by flow.
- The porting on this assembly is large in relation to its capacity. This is done to encourage the use of correspondingly large piping to minimize problems caused by flow induced pressure drop.
- The spool design of the pilot valve allows it to maintain a fixed differential ratio because the areas are created by diameters on the spool that will not wear or change with use.
- The accumulator pilot valve must be set below any reliefs in the pump side of the system or severe heating could occur.
- The relief in this package is meant to be an over-pressure device. It is set higher than the highest setting of the pilot valve and capped.

MANIFOLD FACES

FACE GRID

1	2	3	4
5	6	7	8
9	10	11	12

FACE 2

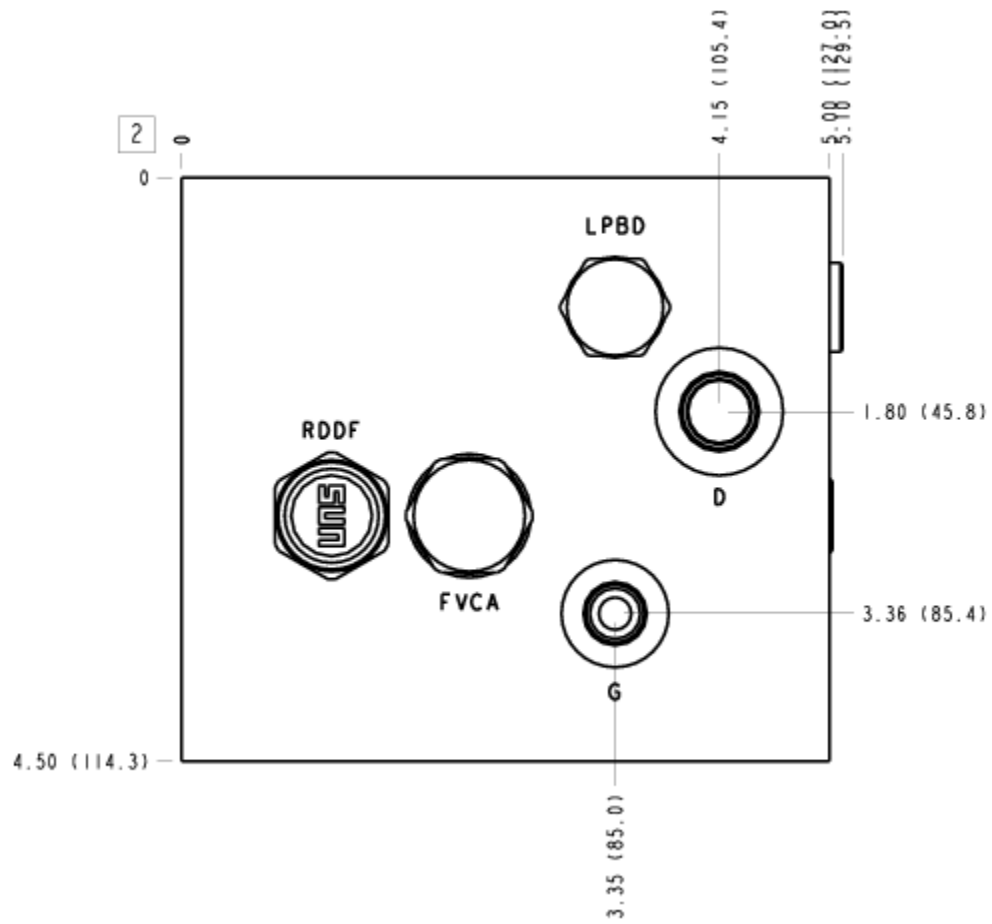

FACE 5

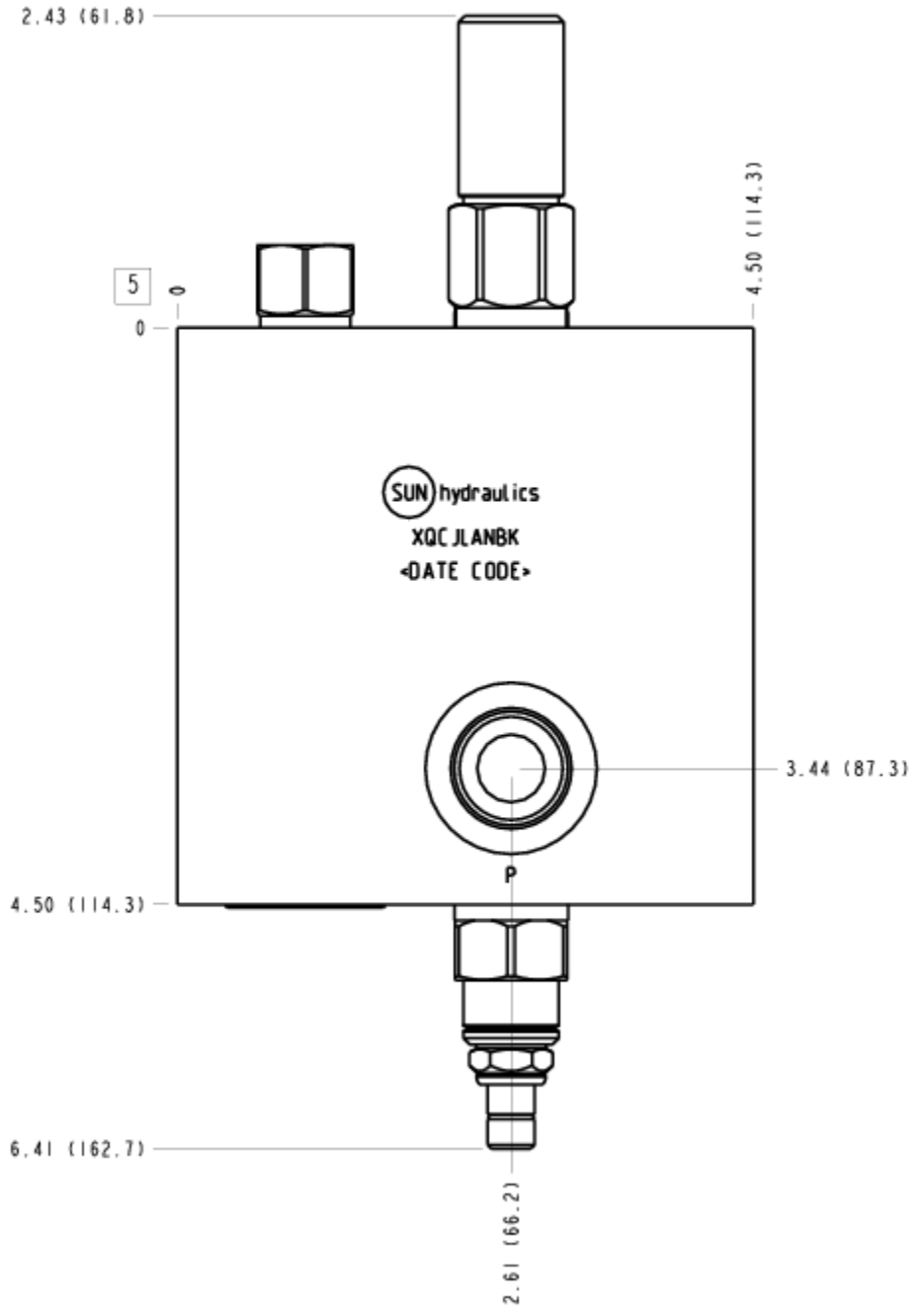

FACE 6

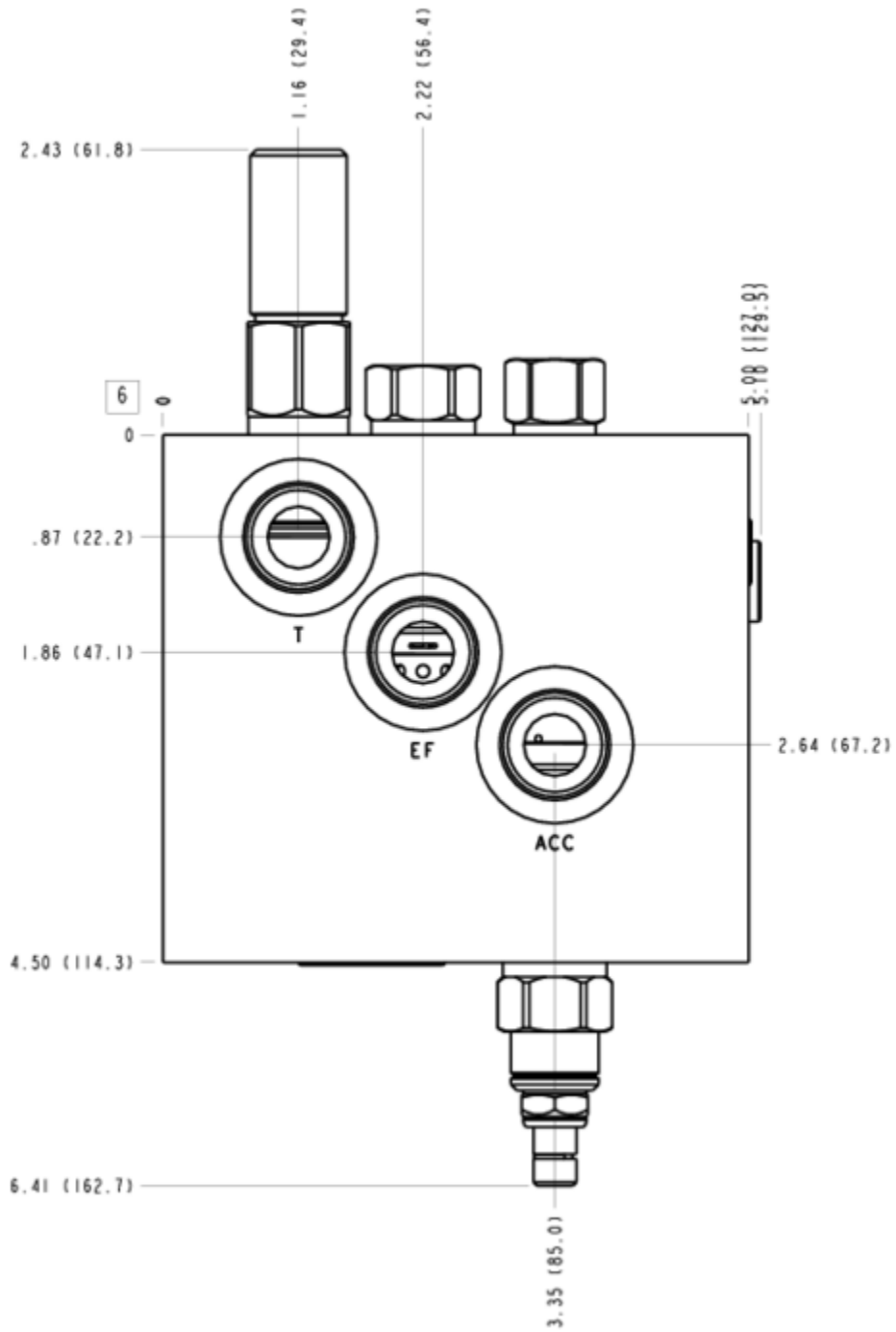

FACE 7

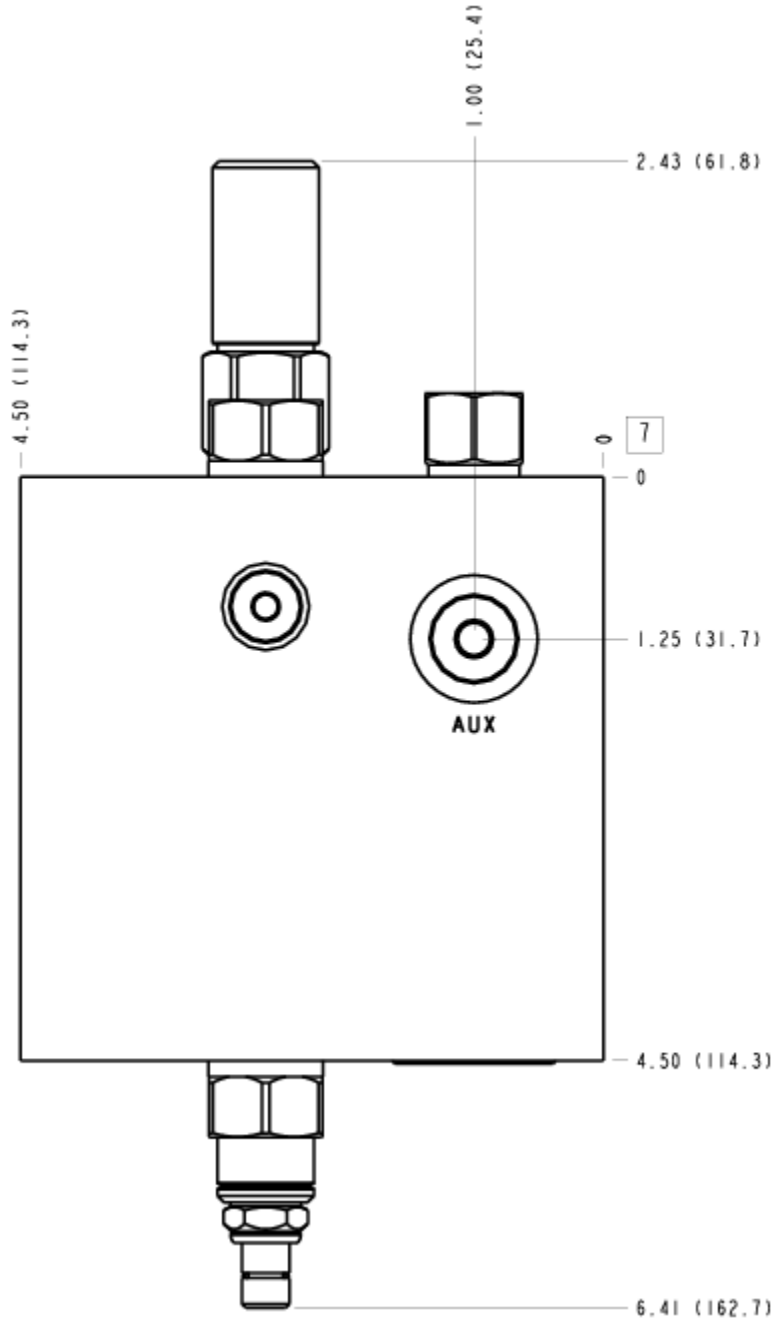

FACE 8

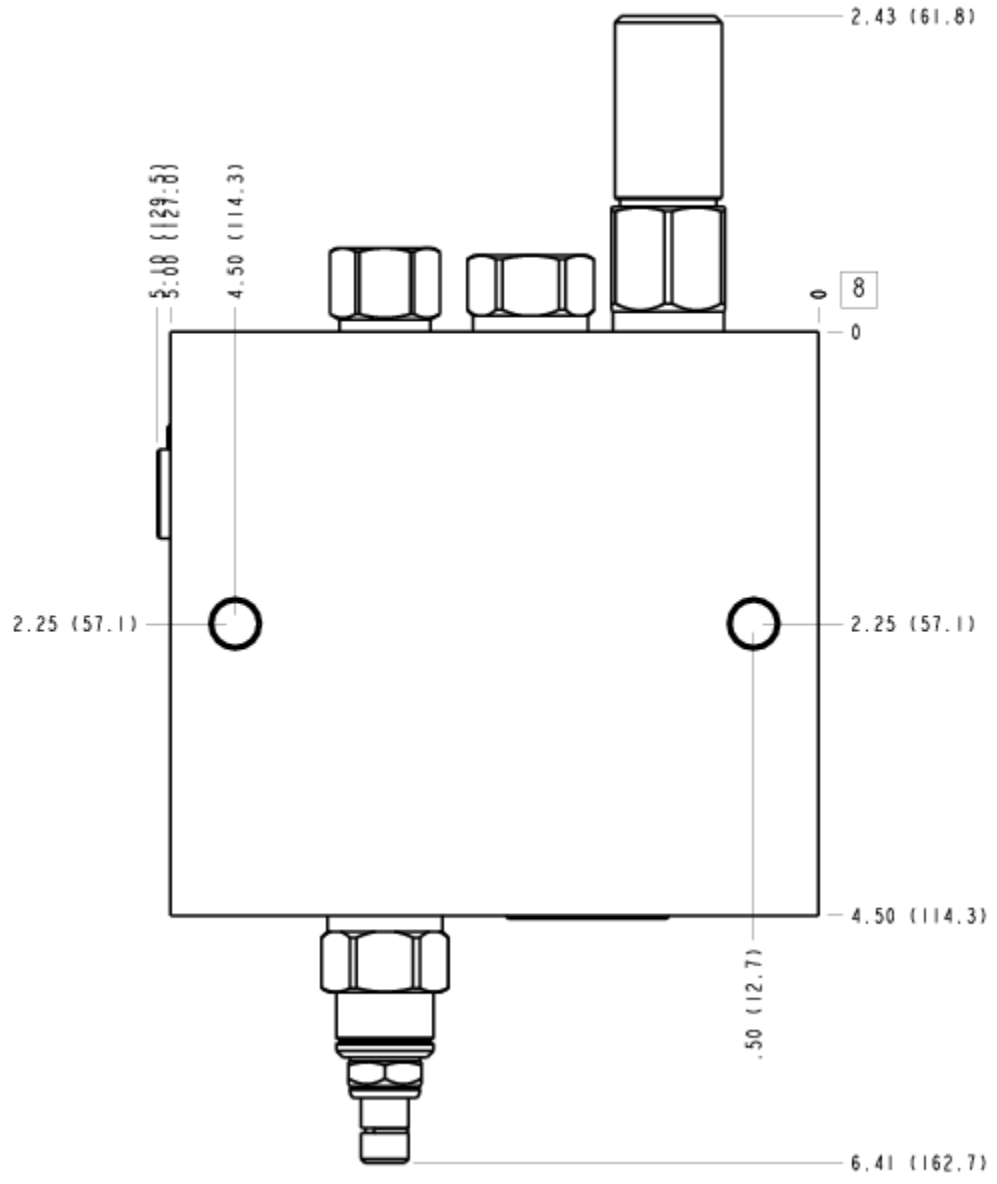

FACE 10

