

This valve assembly is meant to charge an accumulator using a fixed displacement pump. When the pressure reaches the set point of the valve, the pump is unloaded. When the pressure drops to the value determined by the fixed percentage of the pilot valve, the pump is brought back on line to recharge the accumulator. The ventable relief serves a dual purpose as a main stage to unload the pump and as a system over-pressure relief. The assembly has two additional features; a simple circuit that softens the unloading of the pump and provisions for remote sensing of the accumulator pressure.

TECHNICAL DATA NOTE: DATA MAY VARY BY CONFIGURATION. SEE CONFIGURATION SECTION.

Body Type	Line mount
Series	
Capacity	20 gpm
Check Cracking Pressure	50 psi
Mounting Hole Diameter	.41 in.
Mounting Hole Depth	Through
Mounting Hole Quantity	2

- NOTES:**
- **Important:** Carefully consider the maximum system pressure. The pressure rating of the manifold is dependent on the manifold material, with the port type/size a secondary consideration. Manifolds constructed of aluminum are not rated for pressures higher than 3000 psi (210 bar), regardless of the port type/size specified.
 - For detailed information regarding the cartridges contained in this assembly, click on the models codes shown in the Included Components tab.

OPTION SELECTION EXAMPLE: XQEGLANBM

CONTROL	(L) ADJUSTMENT RANGE	(A) SEAL MATERIAL	(N)
L Standard Screw Adjustment	A 1000 - 3000 psi (70 - 210 bar), 1000 psi (70 bar) Standard Setting	N Buna-N	V Viton

PRIMARY CARTRIDGE (B)

B 20% (with QPAB primary cartridge, 20%, accumulator sense, pump unload valve - pilot capacity)
E 10% (with QPAE primary cartridge, 10%, accumulator sense, pump unload valve - pilot capacity)
D 50% (with QPAD primary cartridge, 50%, accumulator sense, pump unload valve - pilot capacity)
C 30% (with QPAC primary cartridge, 30%, accumulator sense, pump unload valve - pilot capacity)
A 15% (with QPAA primary cartridge, 15%, accumulator sense, pump unload valve - pilot capacity)

INCLUDED COMPONENTS

Part	Description	Quantity
A330-006-006*	SAE Plug	1
A330-006-012*	SAE Plug	1
COFOXDN	Cartridge	1
CXFAXCN	Cartridge	1
LPBDXFN	Cartridge	1
QPABLAN	Cartridge - Primary	1
RVEFXAN	Cartridge	1

TECHNICAL FEATURES

- When applying this assembly, a separate drain line is required to prevent erratic operation caused by tank line pressure fluctuations.
- NOTE: Careful consideration should be given when selecting an adjustment range. System pressure drops and flows tend to affect the operation of unloading valves. Low operating pressures combined with low differentials result in a very narrow band between unload and reset, requiring precise system design. High flow rates typically mean high pressure drops, which subtract from the differential the valve has to work with.
- The pressure setting and the resultant reseal pressure are in reference to the port 1 area of the QPA* pilot valve. Pump pressure will be higher and accumulator pressure will be lower due to pressure drop caused by flow. Use of the remote sense for accumulator pressure will minimize the error on the accumulator side of the circuit. Use of the remote sense is highly recommended.
- The porting on this assembly is large in relation to its capacity. This is done to encourage the use of correspondingly large piping to minimize problems caused by flow induced pressure drop.
- The spool design of the pilot valve allows it to maintain a fixed differential ratio because the areas are created by diameters on the spool that will not wear or change with use.
- The accumulator pilot valve must be set below any reliefs in the pump side of the system or severe heating could occur.
- The relief in this package is meant to be an over-pressure device. It is set higher than the highest setting of the pilot valve and capped.

MANIFOLD FACES

FACE GRID

1	2	3	4
5	6	7	8
9	10	11	12

FACE 2

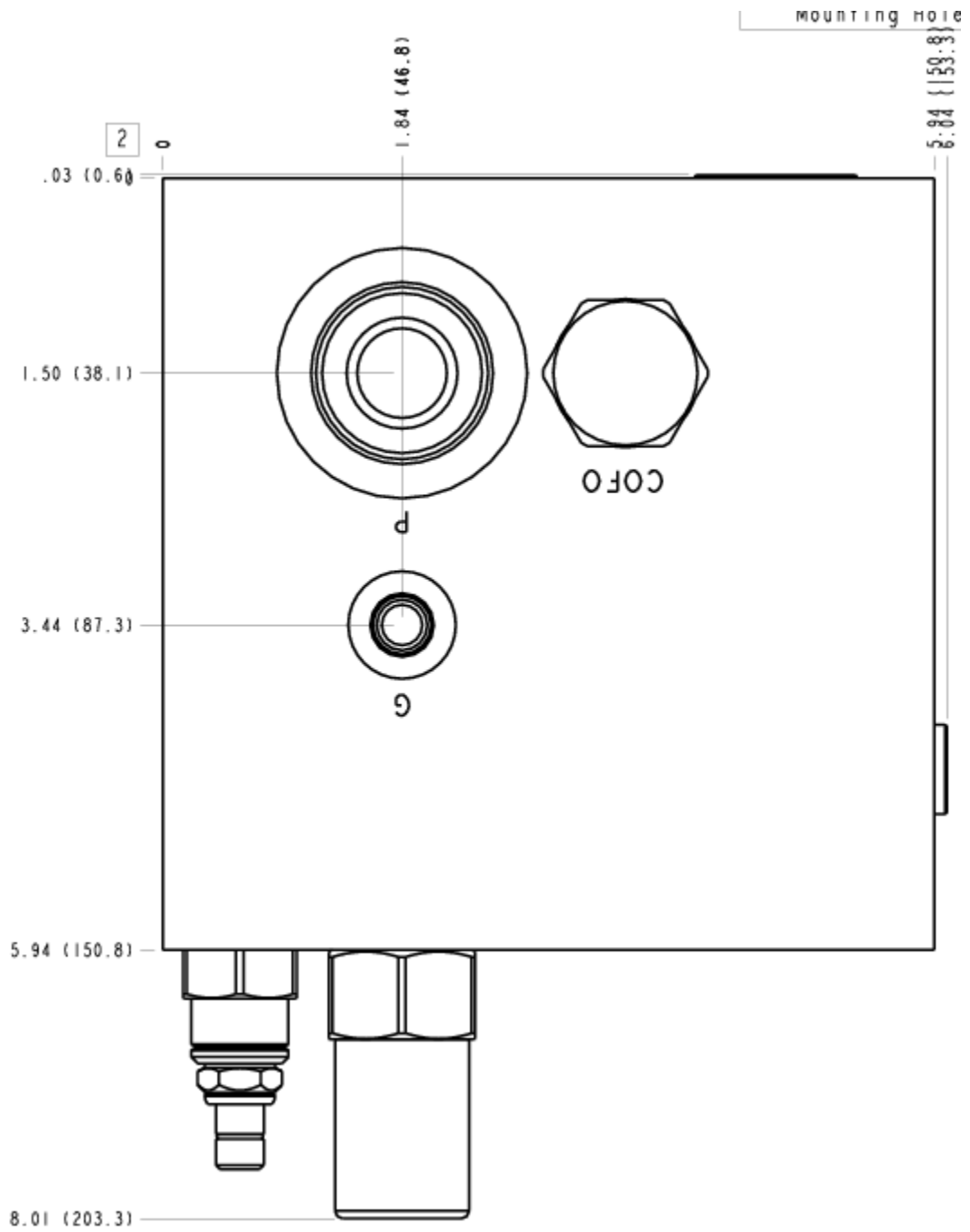

FACE 5

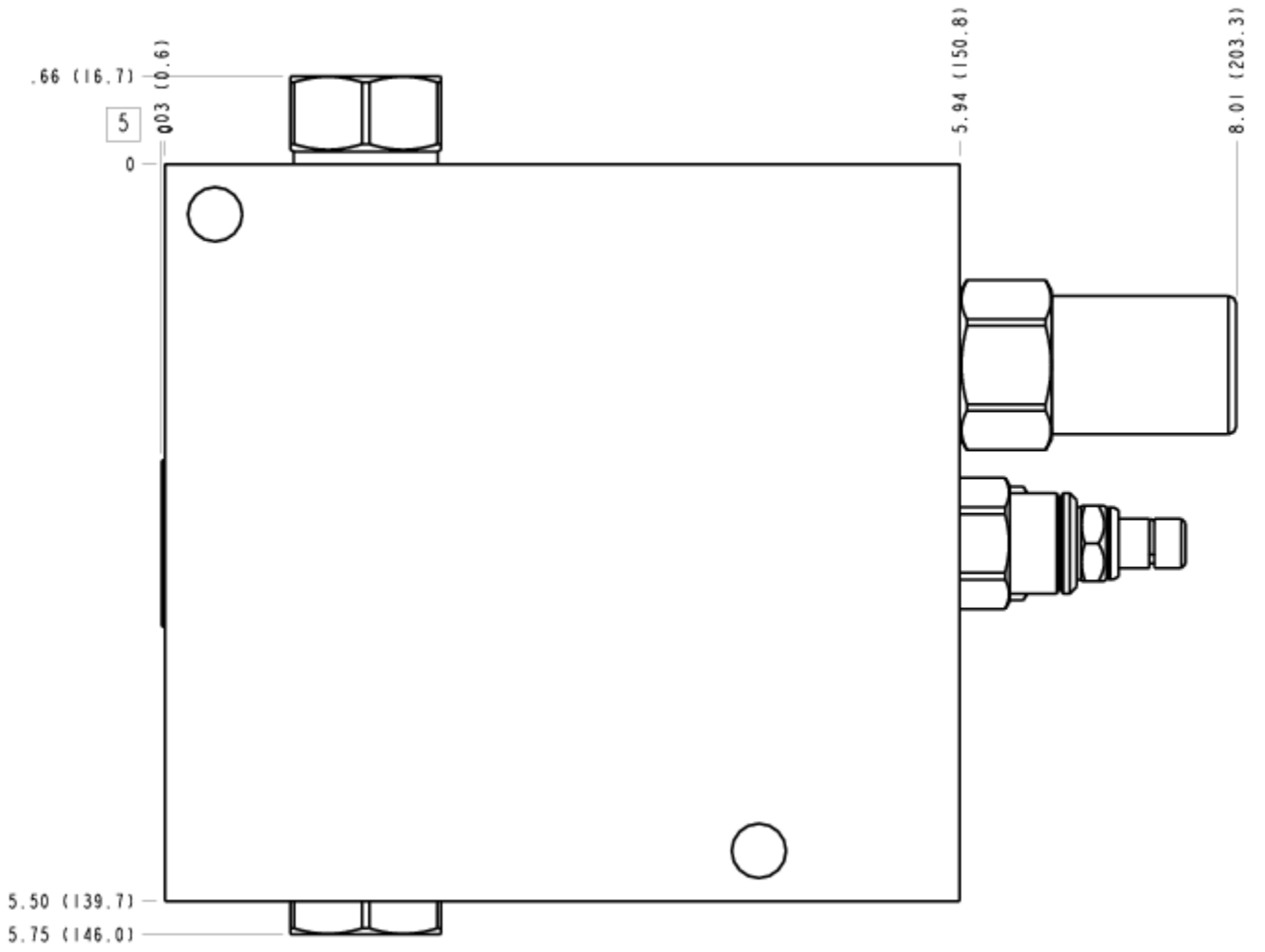

FACE 6

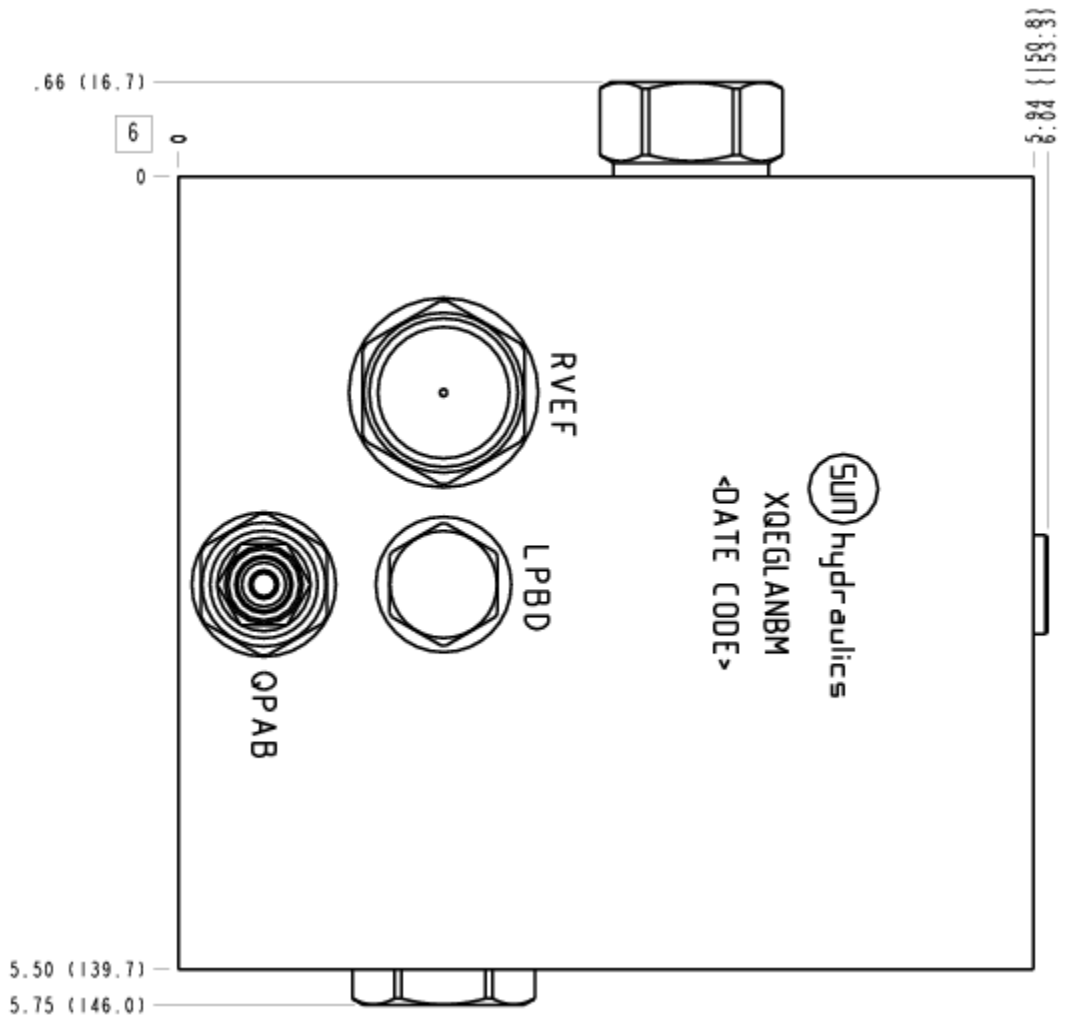

FACE 7

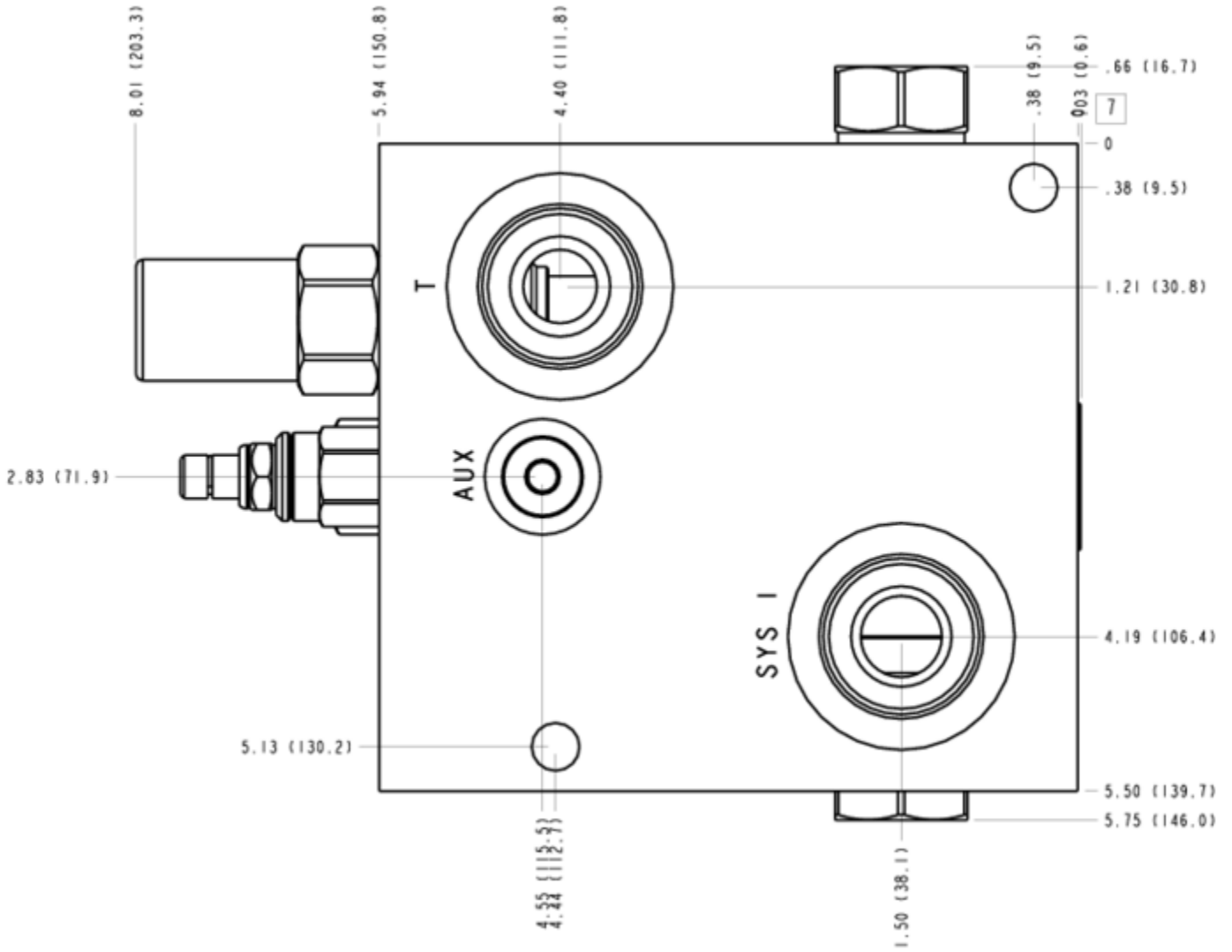

FACE 8

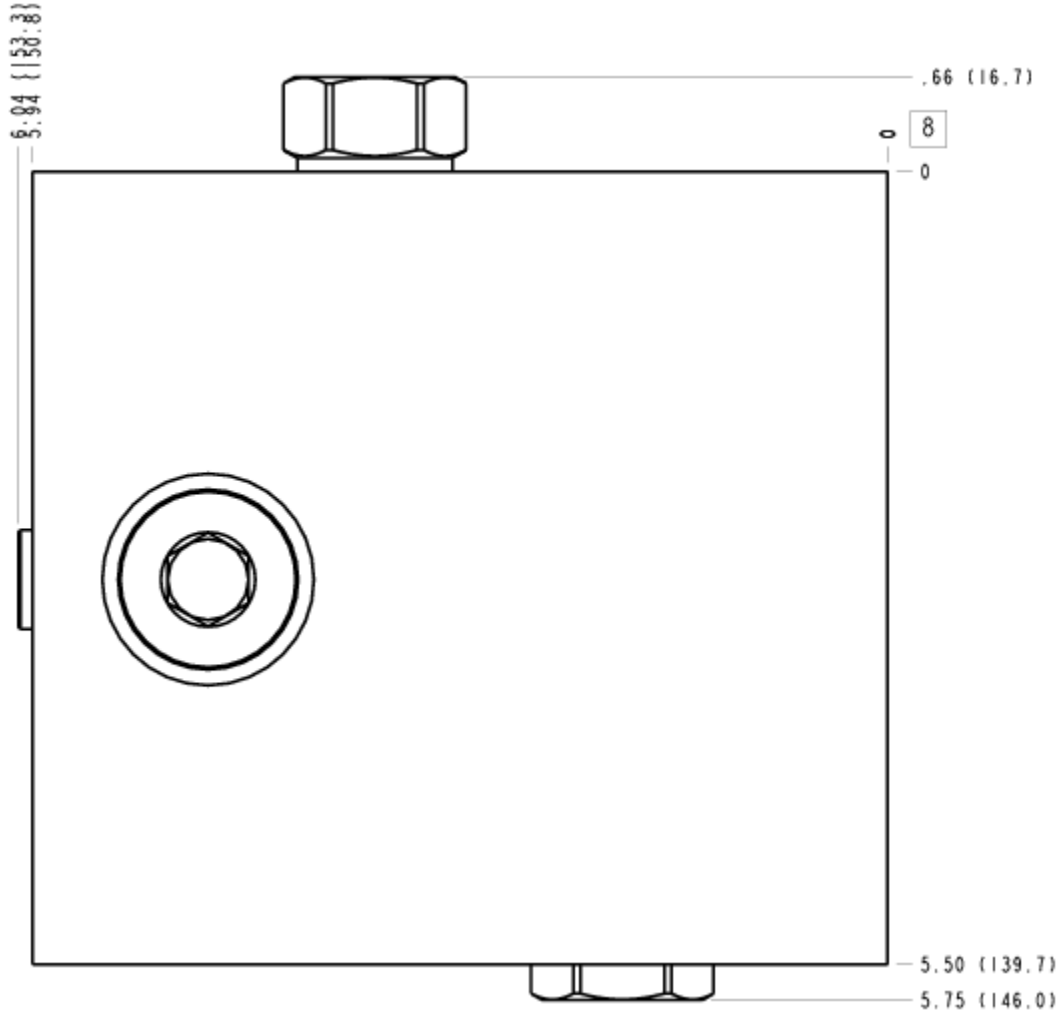

FACE 10

