

TECHNICAL DATA NOTE: DATA MAY VARY BY CONFIGURATION. SEE CONFIGURATION SECTION.

	160 L/min.

OPTION SELECTION EXAMPLE: XQGELANBQ

(L) (A) (N)

L	A	1000 - 3000 psi (70 - 210 bar), 1000 psi (70 bar)	N
C			V

PRIMARY CARTRIDGE

(B)

B	20% (with QPAB primary cartridge, 20%,	-)
D	50% (with QPAD primary cartridge, 50%,	-)
C	30% (with QPAC primary cartridge, 30%,	-)
A	15% (with QPAA primary cartridge, 15%,	-)

INCLUDED COMPONENTS

Part	Description	Quantity
CXHAXCN	Cartridge	1
QPABLAN	Cartridge - Primary	1
RVGFXAN	Cartridge	1

MANIFOLD FACES

FACE GRID

1	2	3	4
5	6	7	8
9	10	11	12

FACE 2

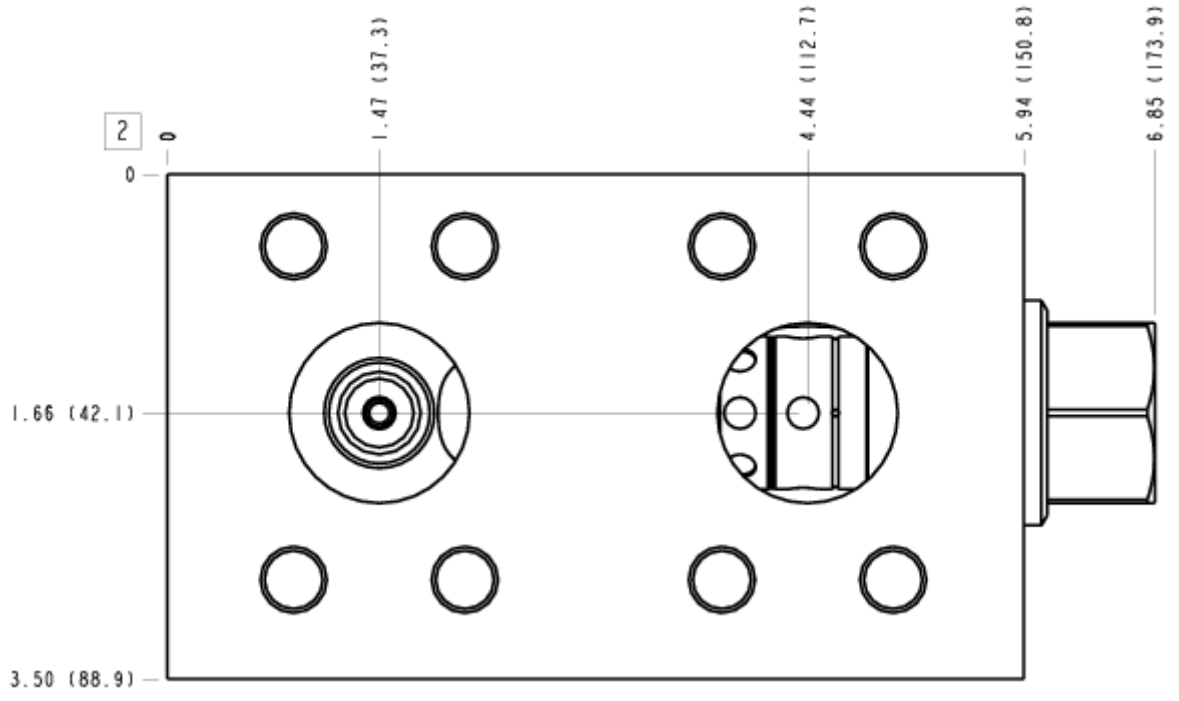

FACE 5

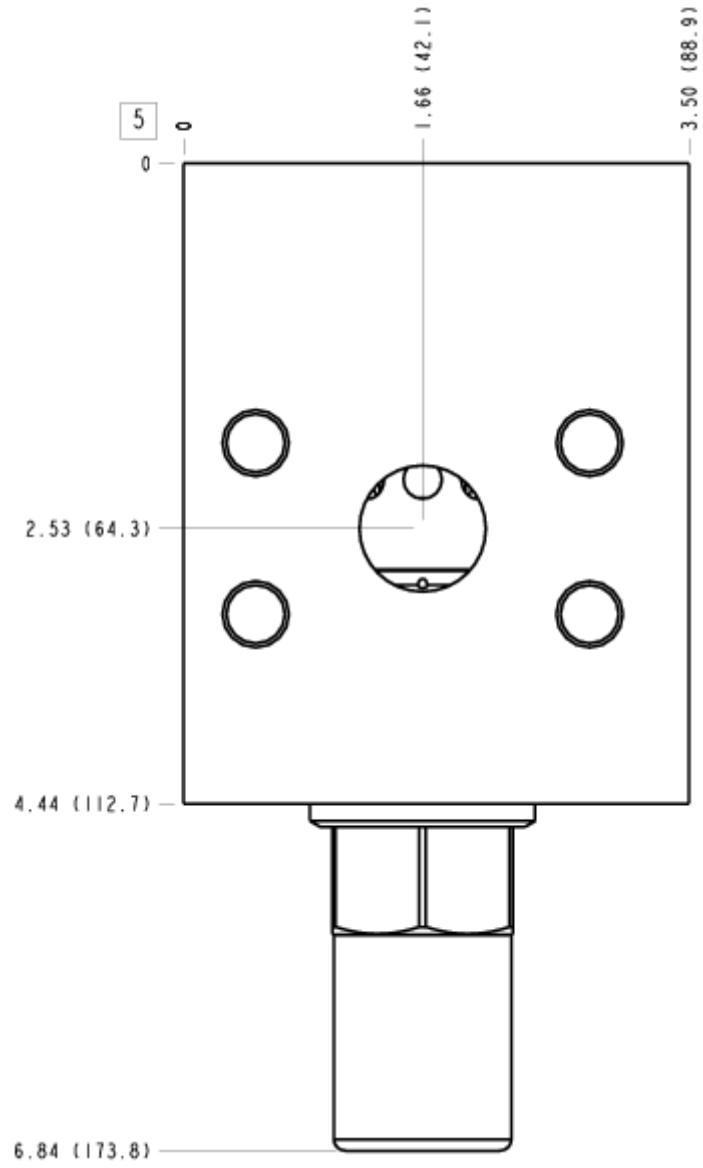

FACE 6

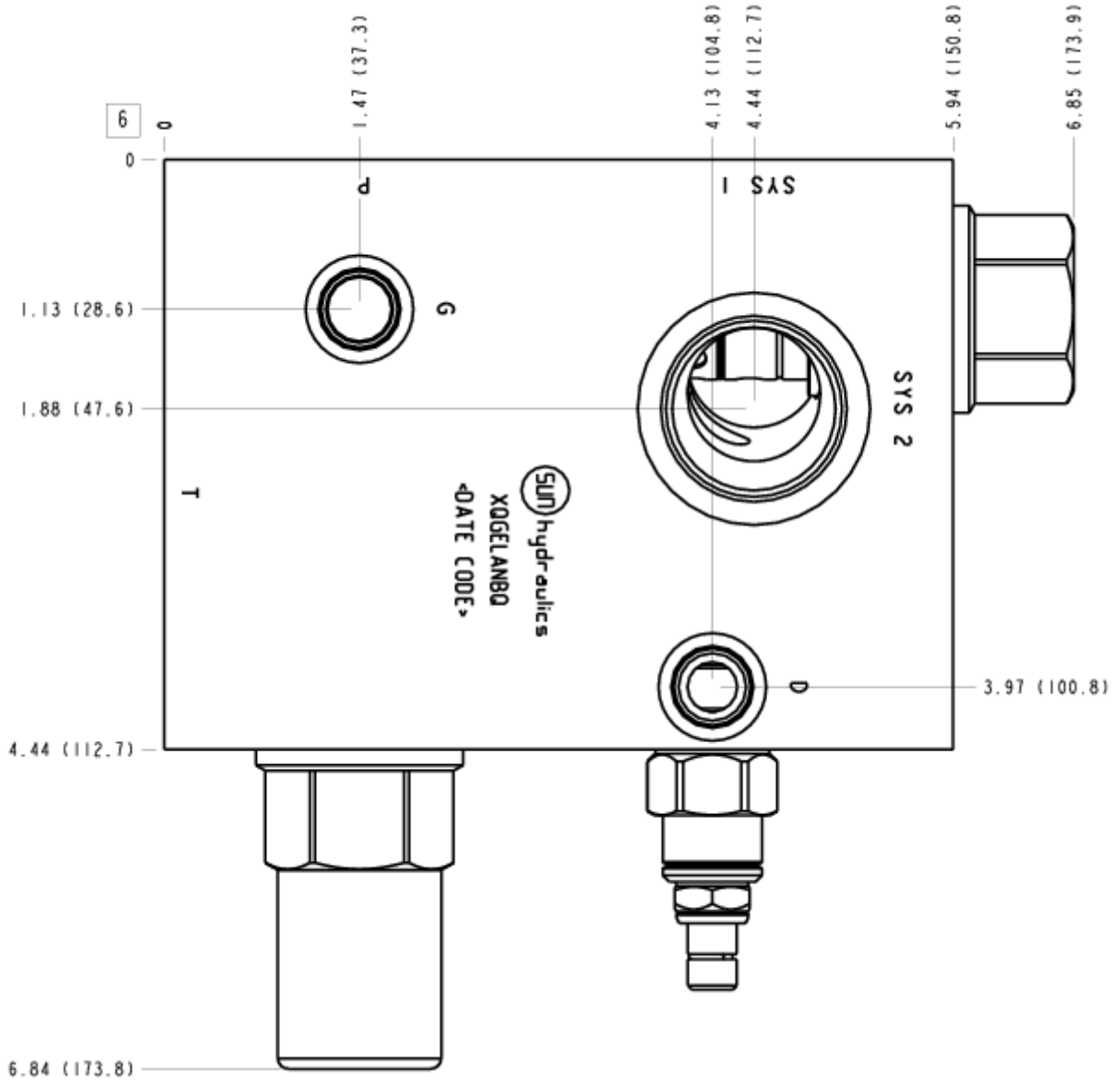

FACE 7

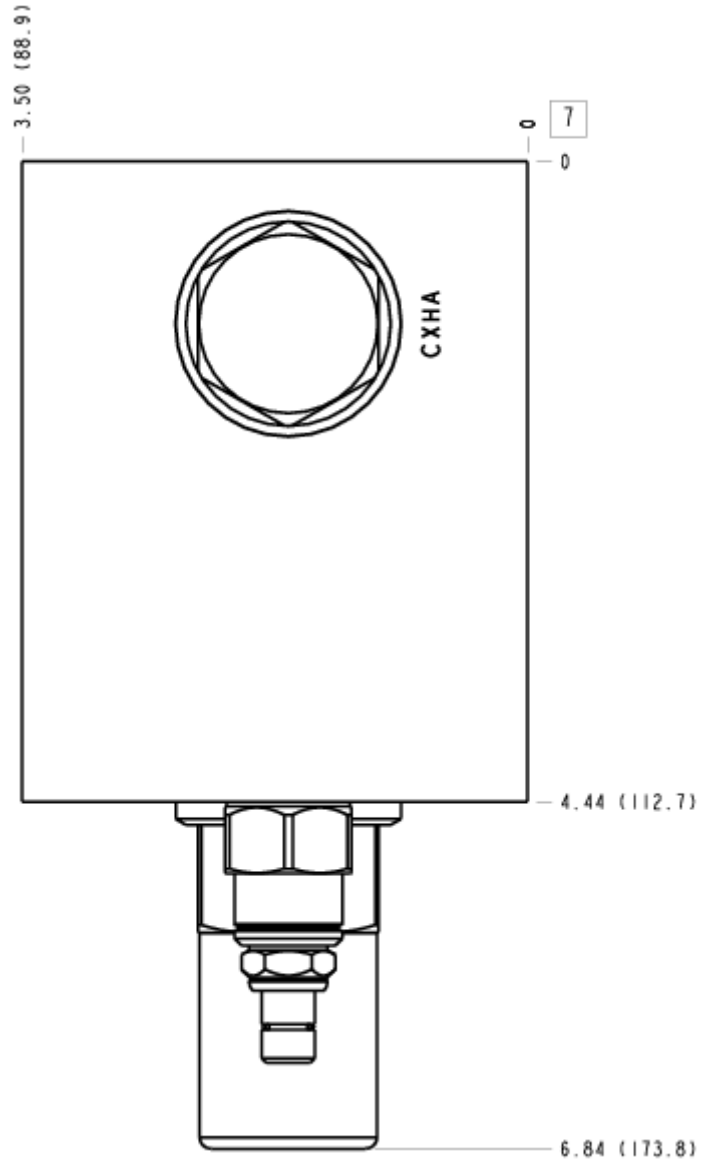

FACE 10

