

OPTION SELECTION EXAMPLE: XQIFLANBN

CONTROL	(L) ADJUSTMENT RANGE	(A) SEAL MATERIAL	(N)
L Standard Screw Adjustment	A 1000 - 3000 psi (70 - 210 bar), 1000 psi (70 bar) Standard Setting	N Buna-N	V Viton

PRIMARY CARTRIDGE **(B)**

B 20% (with QPAB primary cartridge, 20%, detector de presión en el acumulador, descargador de bomba válvula - capacidad de pilotaje)
E 10% (with QPAE primary cartridge, 10%, detector de presión en el acumulador, descargador de bomba válvula - capacidad de pilotaje)
D 50% (with QPAD primary cartridge, 50%, detector de presión en el acumulador, descargador de bomba válvula - capacidad de pilotaje)
C 30% (with QPAC primary cartridge, 30%, detector de presión en el acumulador, descargador de bomba válvula - capacidad de pilotaje)
A 15% (with QPAA primary cartridge, 15%, detector de presión en el acumulador, descargador de bomba válvula - capacidad de pilotaje)

INCLUDED COMPONENTS

Part	Description	Quantity
A330-006-006*	SAE Plug	1
A330-006-012*	SAE Plug	1
CXJAXCN	Cartridge	1
LPBDXDN	Cartridge	1
QPABLAN	Cartridge - Primary	1
RVIFXAN	Cartridge	1

MANIFOLD FACES

FACE GRID

1	2	3	4
5	6	7	8
9	10	11	12

FACE 2

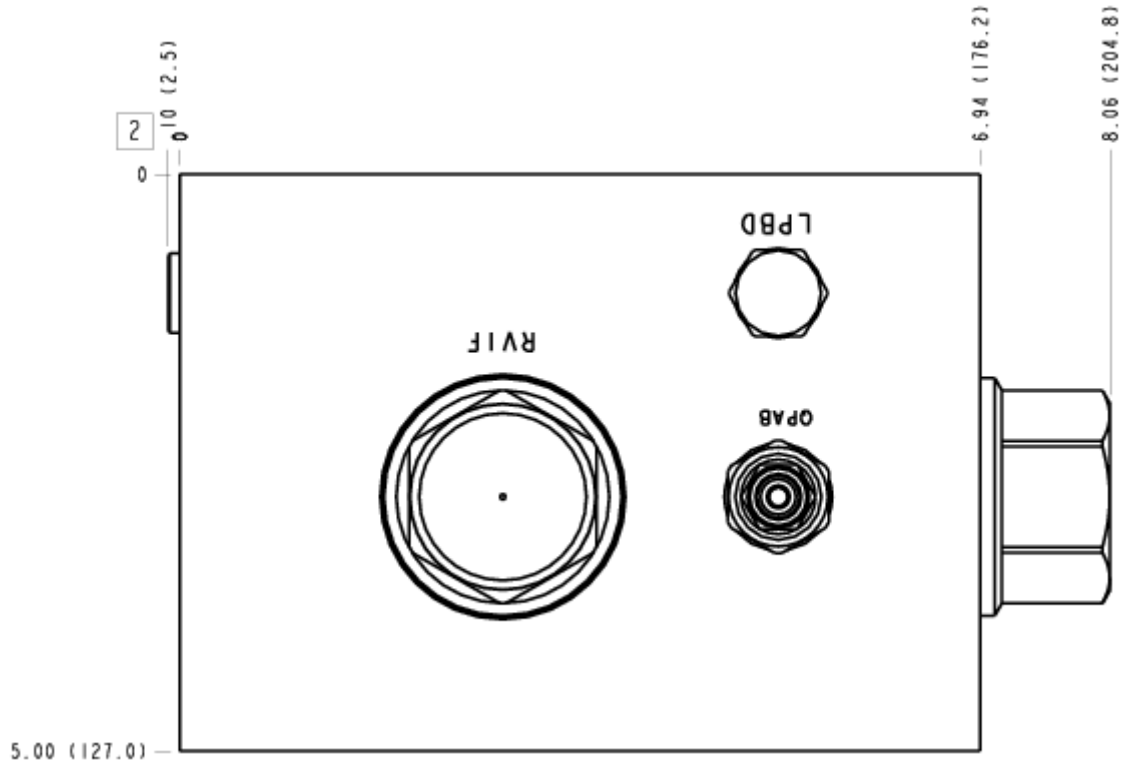

FACE 6

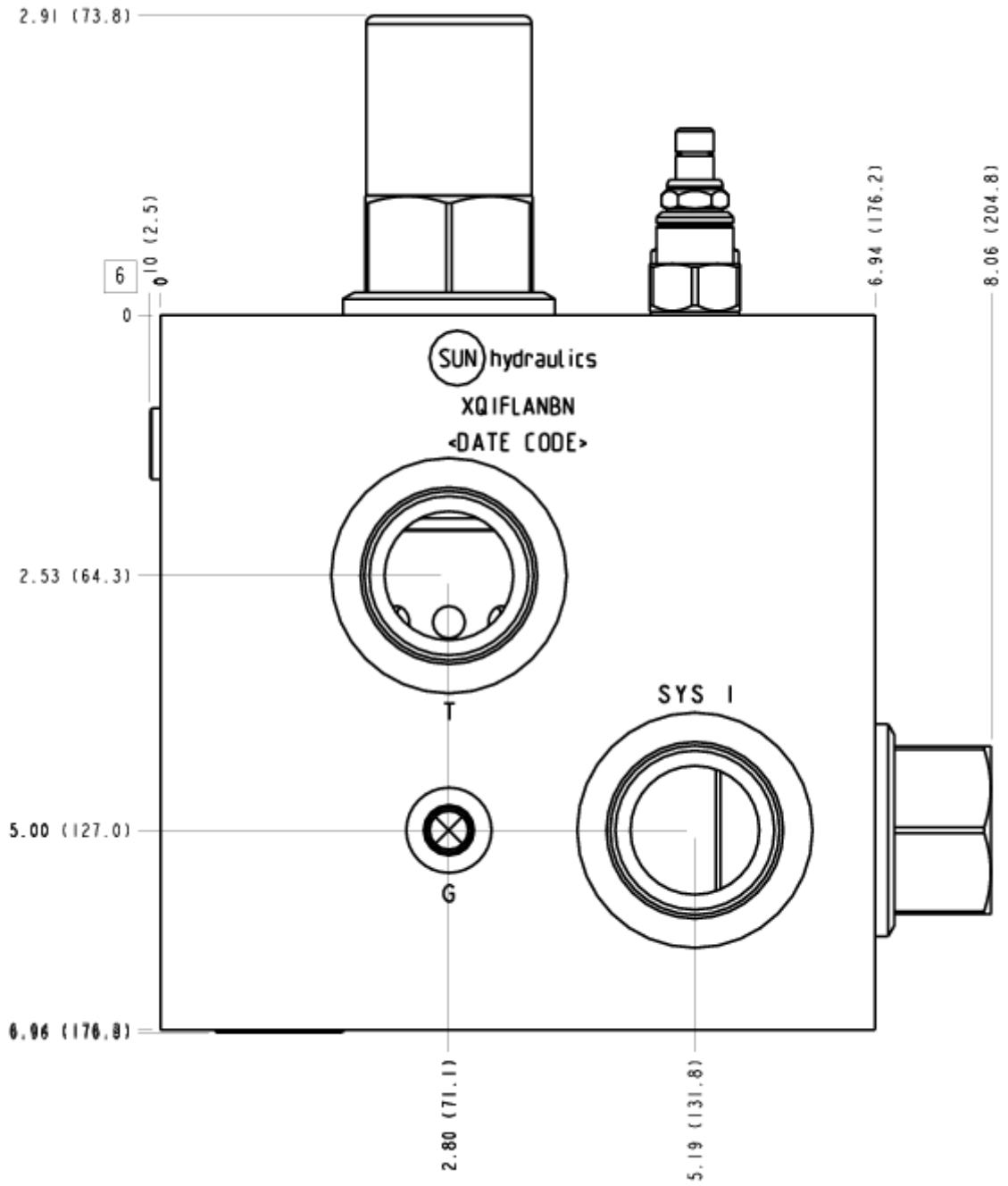

FACE 7

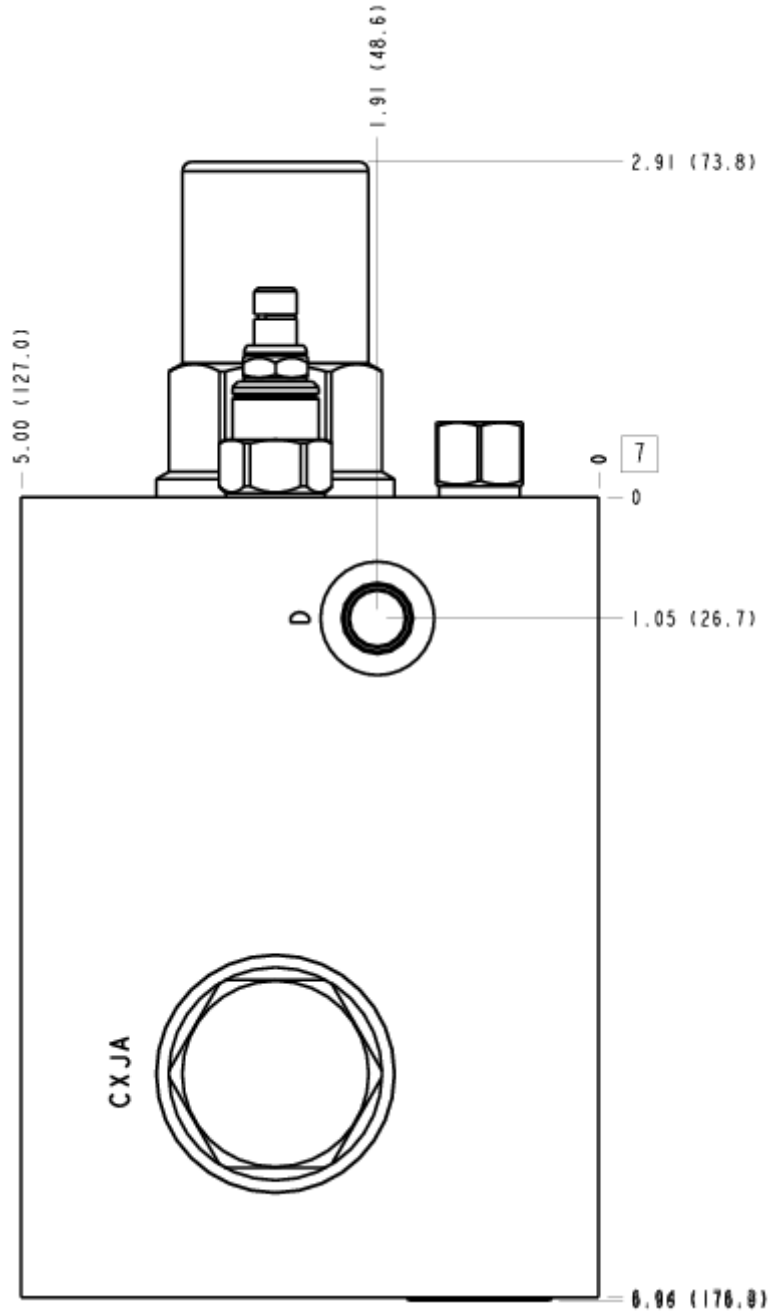

FACE 8

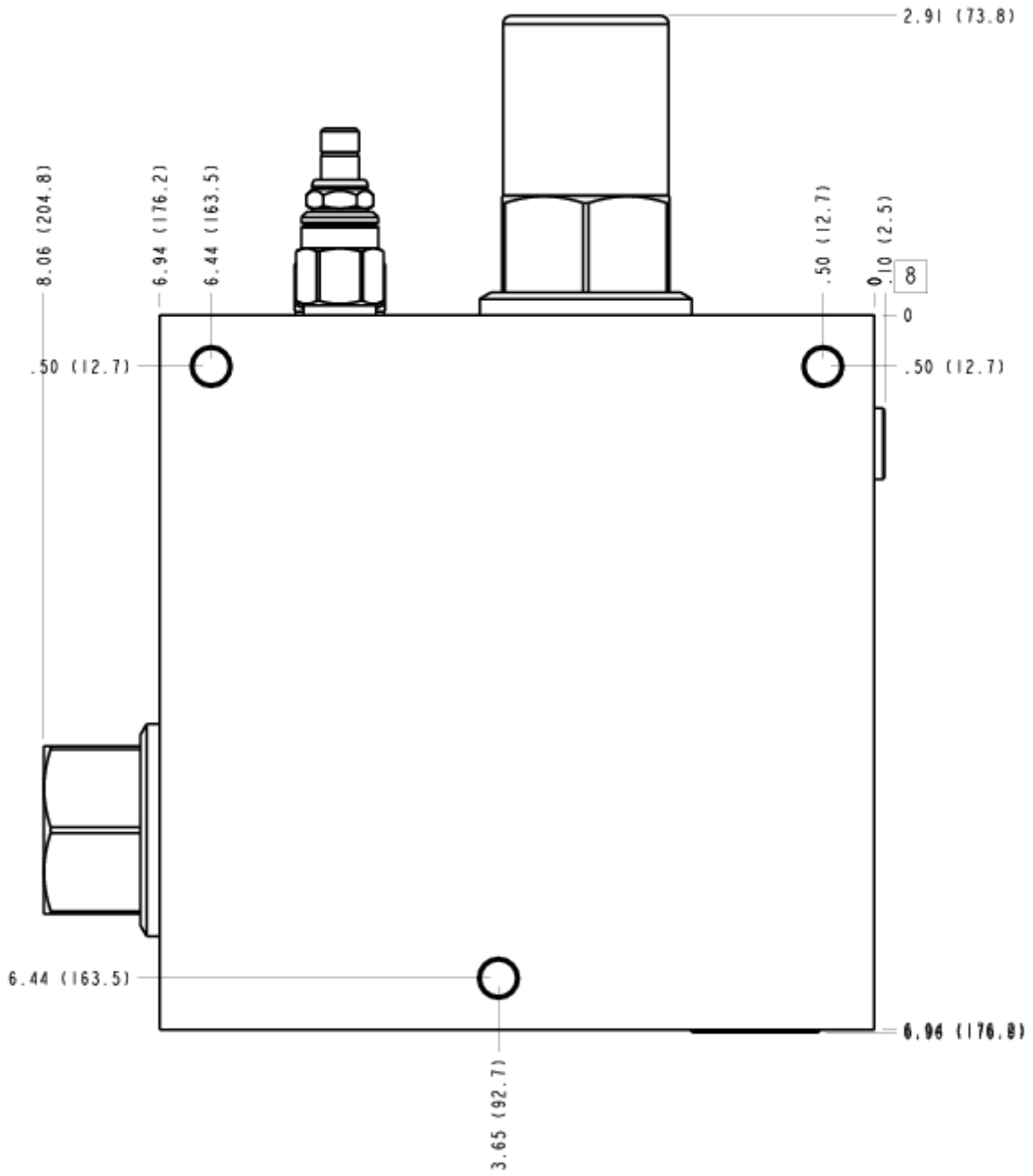

FACE 10

