

TECHNICAL DATA NOTE: DATA MAY VARY BY CONFIGURATION. SEE CONFIGURATION SECTION.

	1 L/min.
	8.6 mm
	Through
	1

OPTION SELECTION EXAMPLE: XRAKLANFI912

(L)

(A)

(N)

L	A 25 - 3000 psi (1,7 - 210 bar), 1000 psi (70 bar)	N V
----------	---	---------------

INCLUDED COMPONENTS

Part	Description	Quantity
DTAFMHN912	Cartridge	1
RBACLAN	Cartridge - Primary	1

TECHNICAL FEATURES

- FLeX

MANIFOLD FACES

FACE GRID

1	2	3	4
5	6	7	8
9	10	11	12

FACE 2

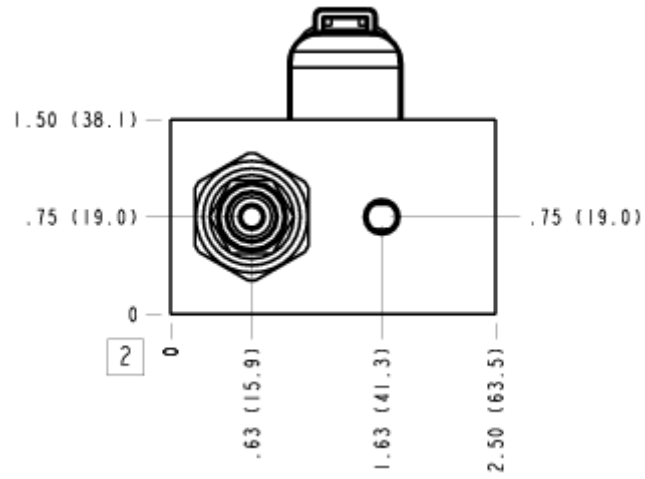

FACE 5

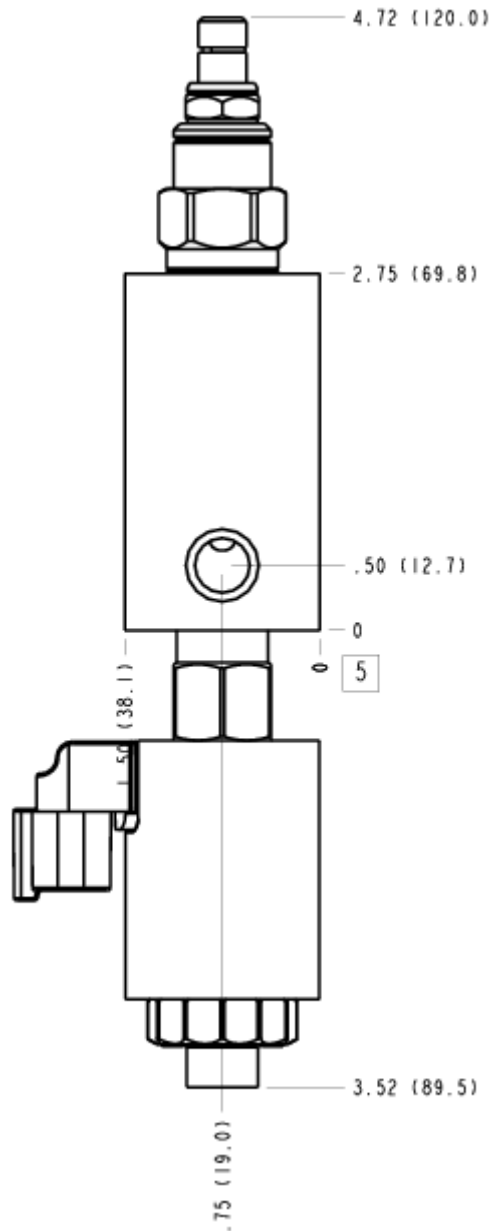

FACE 6

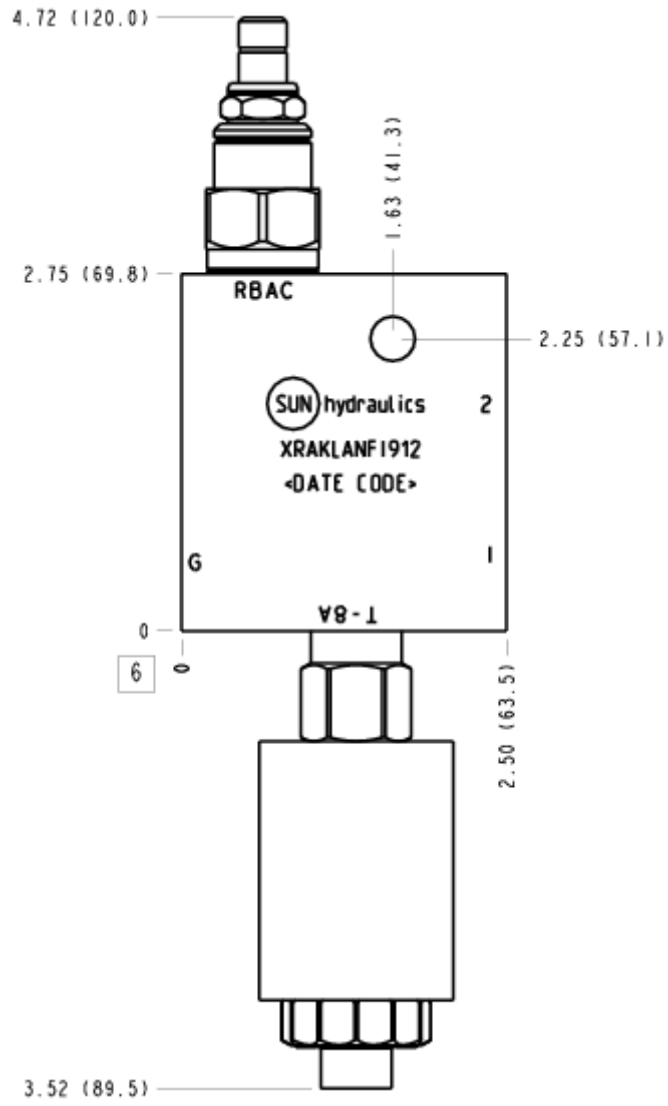

FACE 7

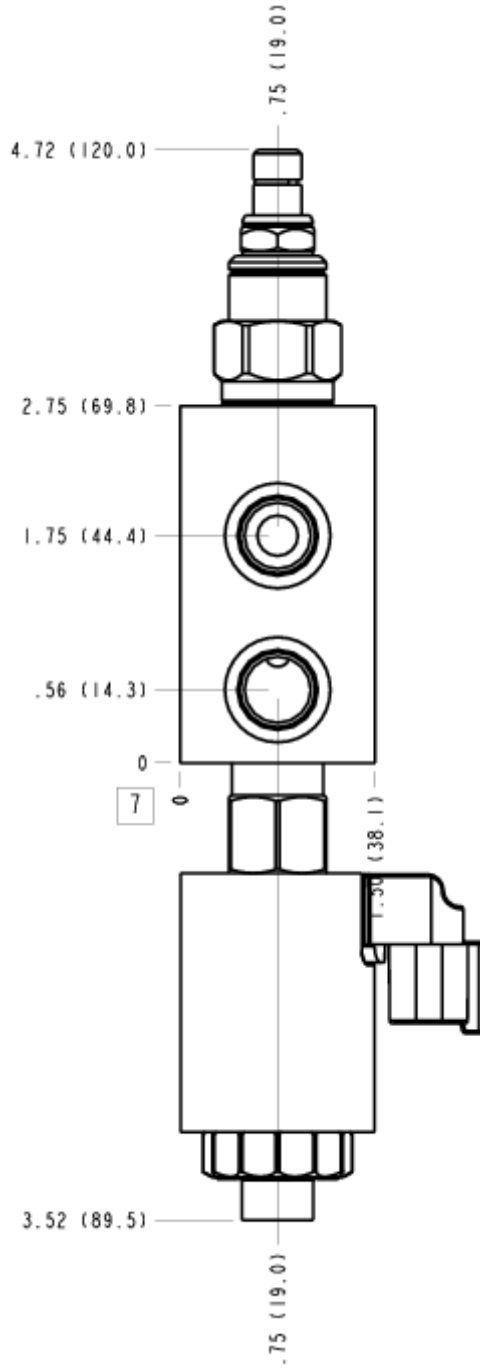

FACE 8

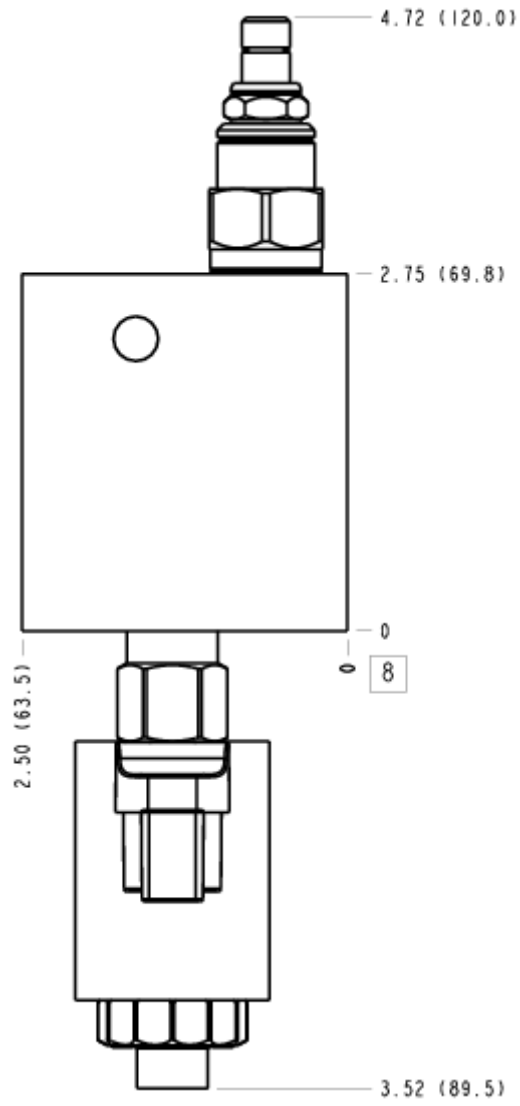

FACE 10

