

OPTION SELECTION EXAMPLE: XRCXLANFK912

CONTROL	(L) ADJUSTMENT RANGE	(A) SEAL MATERIAL	(N)
L Standard Screw Adjustment	A 100 - 3000 psi (7 - 210 bar), 1000 psi (70 bar) Standard Setting	N Buna-N	
C Tamper Resistant - Factory Set	B 50 - 1500 psi (3,5 - 105 bar), 1000 psi (70 bar) Standard Setting	V Viton	
	C 150 - 6000 psi (10,5 - 420 bar), 1000 psi (70 bar) Standard Setting		
	D 25 - 800 psi (1,7 - 55 bar), 400 psi (28 bar) Standard Setting		
	E 25 - 400 psi (1,7 - 28 bar), 200 psi (14 bar) Standard Setting		
	W 150 - 4500 psi (10,5 - 315 bar), 1000 psi (70 bar) Standard Setting		

INCLUDED COMPONENTS

Part	Description	Quantity
DTAFMHN912	Cartridge	1
RVCALAN	Cartridge - Primary	1

MANIFOLD FACES

FACE GRID

1	2	3	4
5	6	7	8
9	10	11	12

FACE 2

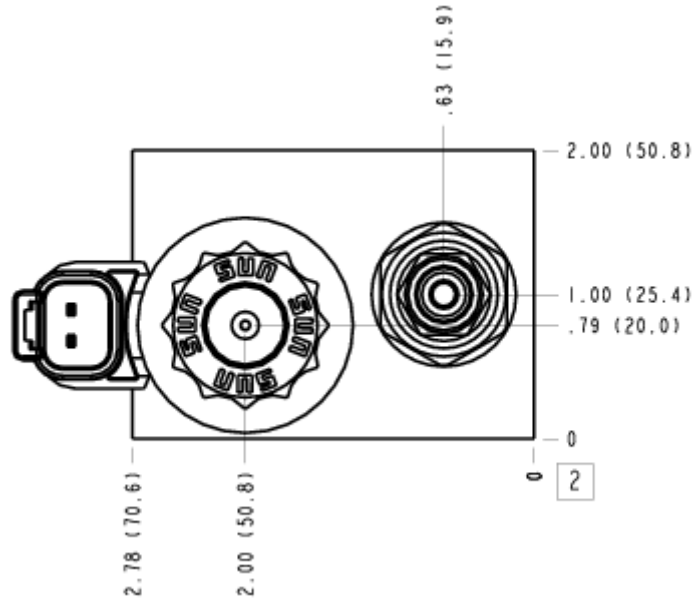

FACE 5

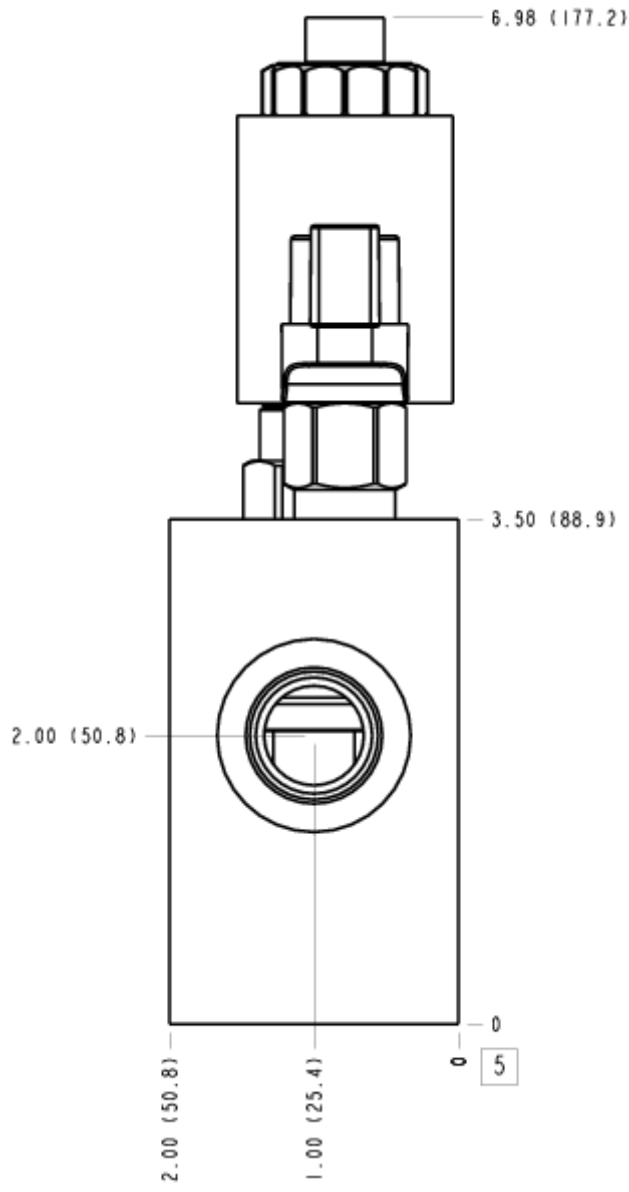

FACE 6

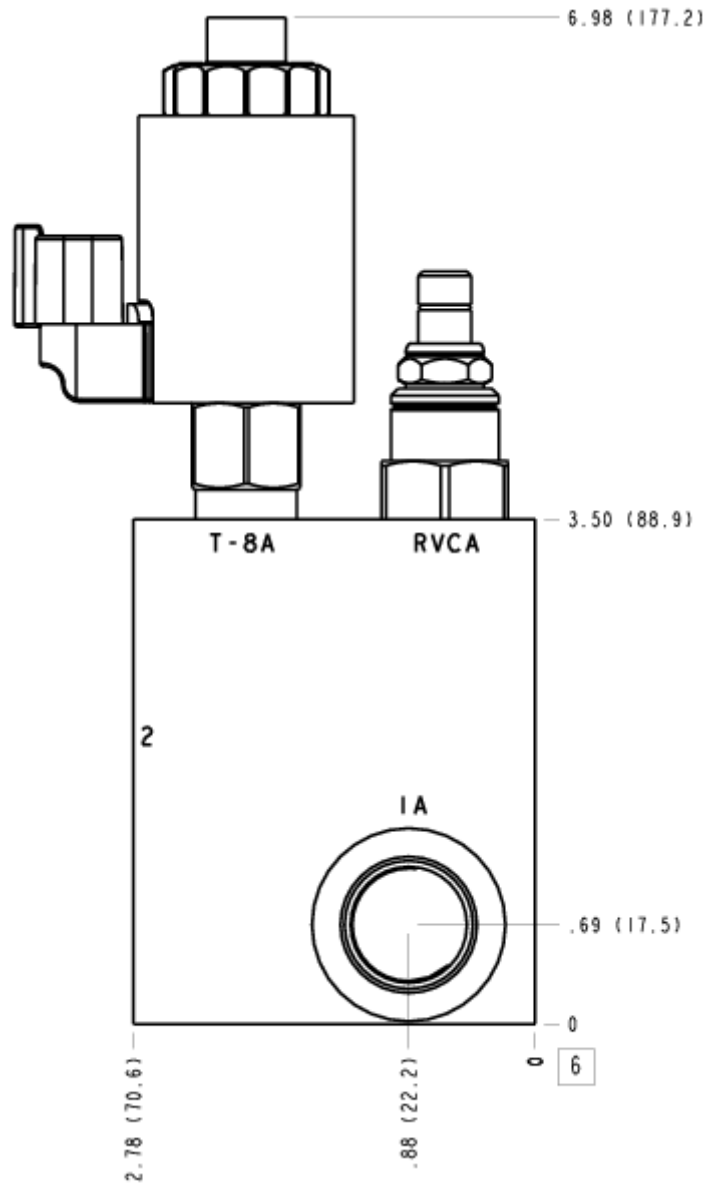

FACE 7

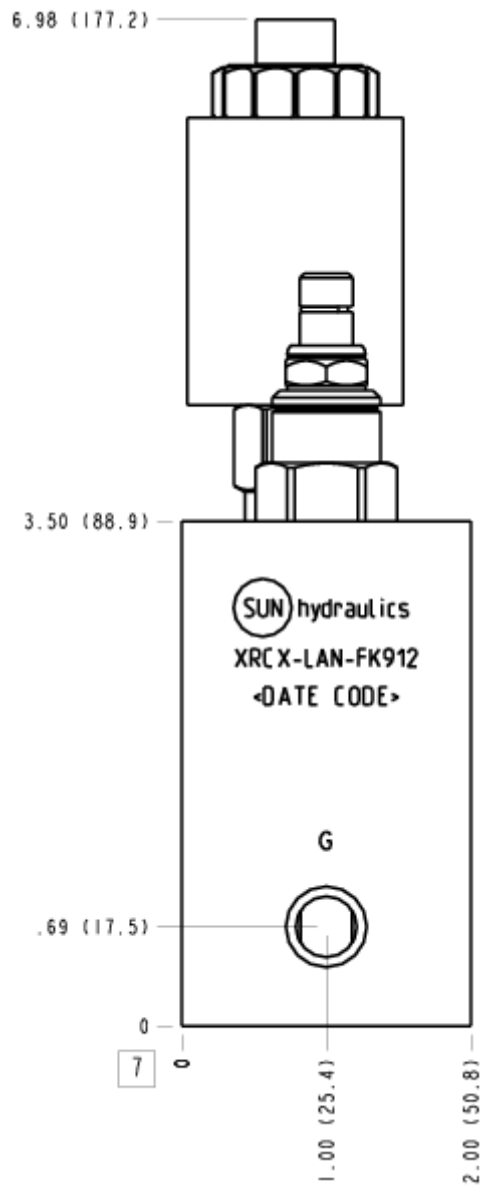

FACE 8

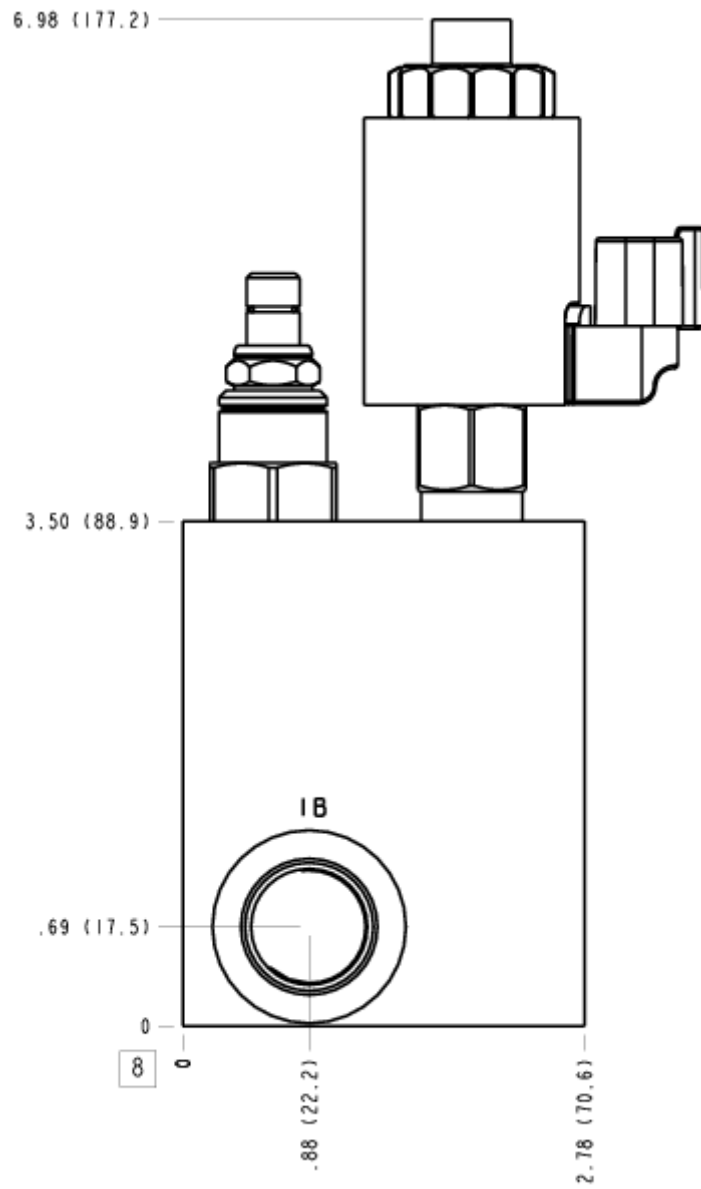

FACE 10

