

Normally Open

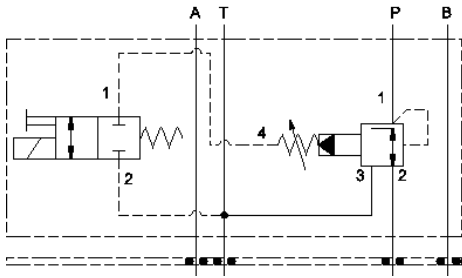

Normally Closed

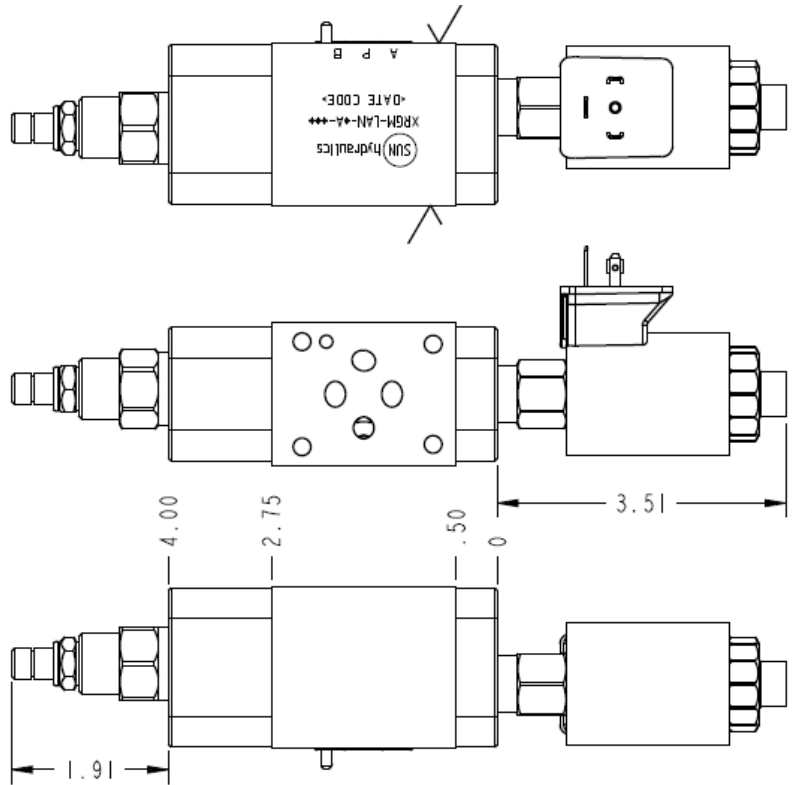

INCH/
THIRD ANGLE

TECHNICAL DATA NOTE: DATA MAY VARY BY CONFIGURATION. SEE CONFIGURATION SECTION.

Body Type	aplilables
Interface	ISO 03
Capacity	40 L/min.
Body Features	Reducer/reliever on P
Seal Plate Included (see notes)	No
Stack Height	44,5 mm

OPTION SELECTION EXAMPLE: XRGM LANFA912

CONTROL	(L) ADJUSTMENT RANGE	(A) SEAL MATERIAL	(N)
L Standard Screw Adjustment	A 100 - 3000 psi (7 - 210 bar), 200 psi (14 bar) Standard Setting	N Buna-N	
	B 50 - 1500 psi (3,5 - 105 bar), 200 psi (14 bar) Standard Setting	V Viton	
	D 25 - 800 psi (1,7 - 55 bar), 200 psi (14 bar) Standard Setting		
	N 60 - 800 psi (4 - 55 bar), 200 psi (14 bar) Standard Setting		
	W 150 - 4500 psi (10,5 - 315 bar), 200 psi (14 bar) Standard Setting		

INCLUDED COMPONENTS

Part	Description	Quantity
500-001-012*	O-Ring	4
811-001-006*	Pin	1
850-004-218*	Plug	1
DTAFMHN912	Cartridge	1
PVDALAN	Cartridge - Primary	1

MANIFOLD FACES

FACE GRID

1	2	3	4
5	6	7	8
9	10	11	12

FACE 2

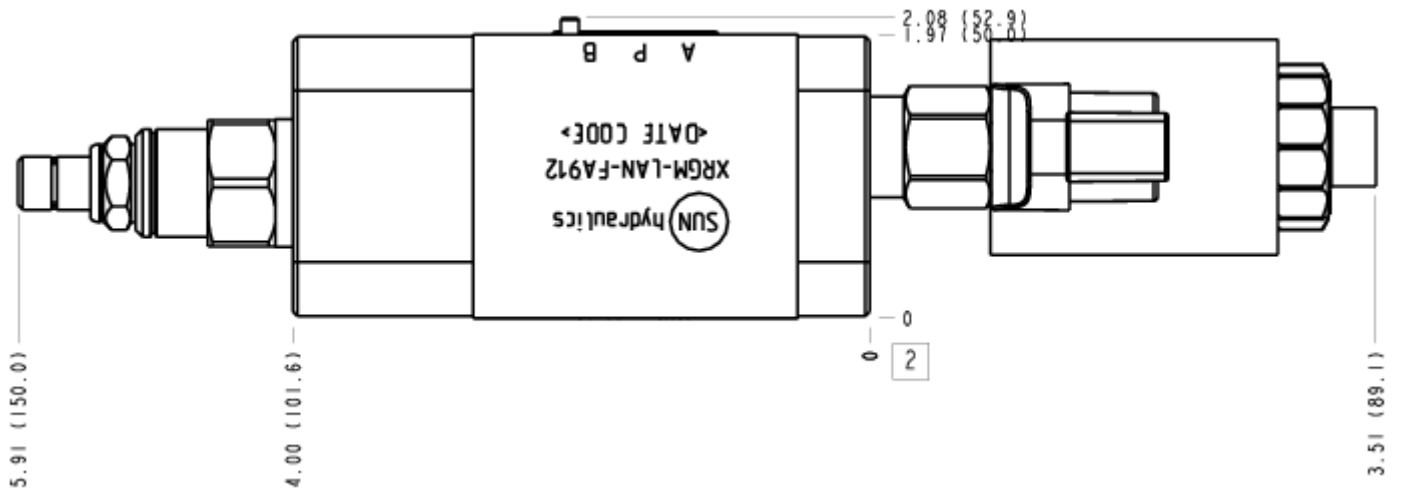

FACE 5

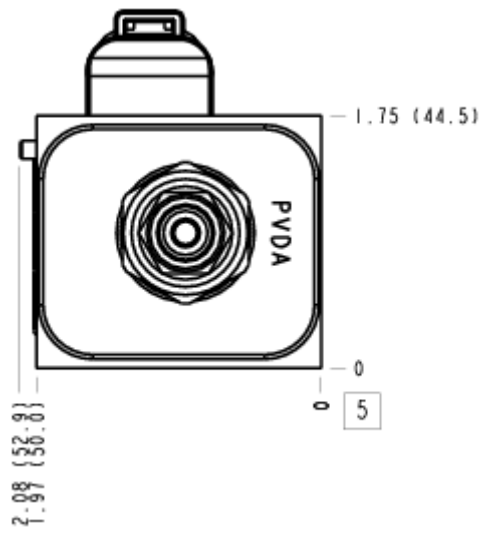

FACE 6

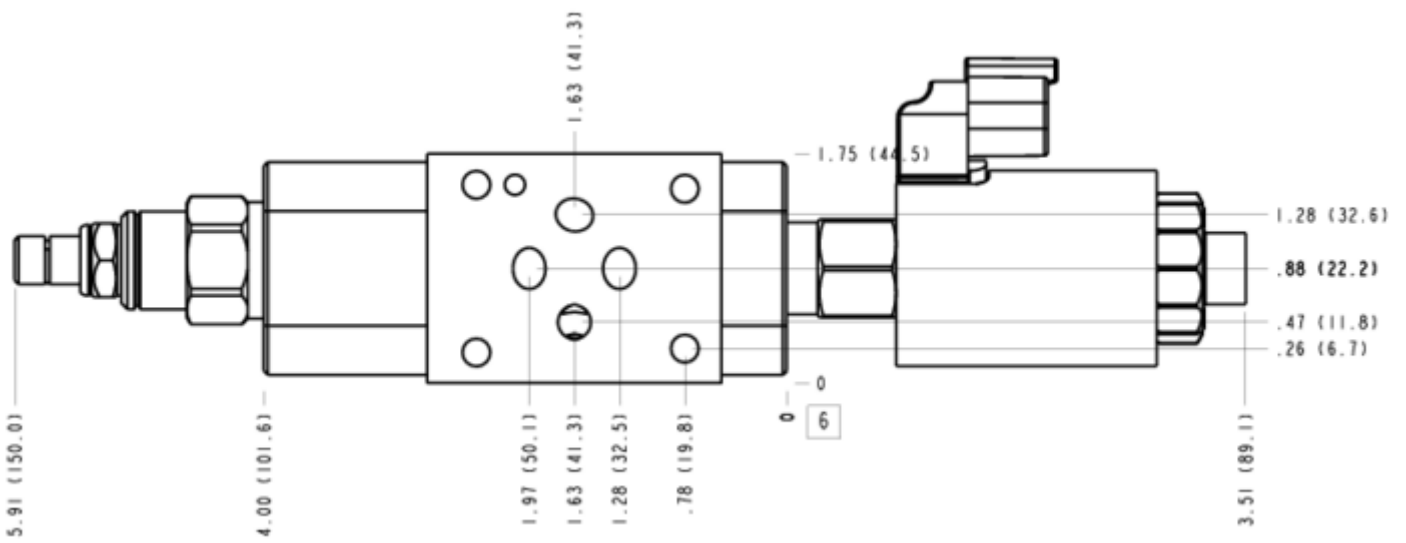

FACE 7

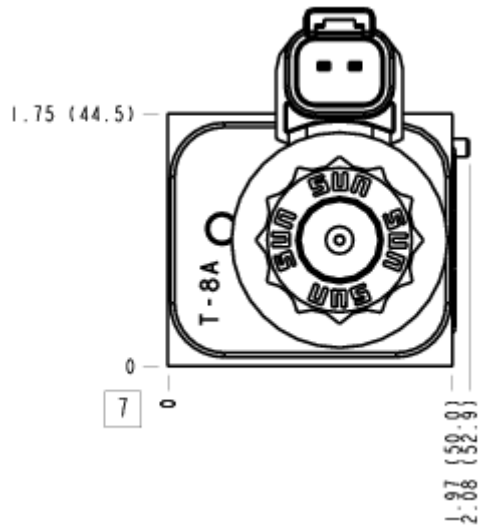

FACE 8

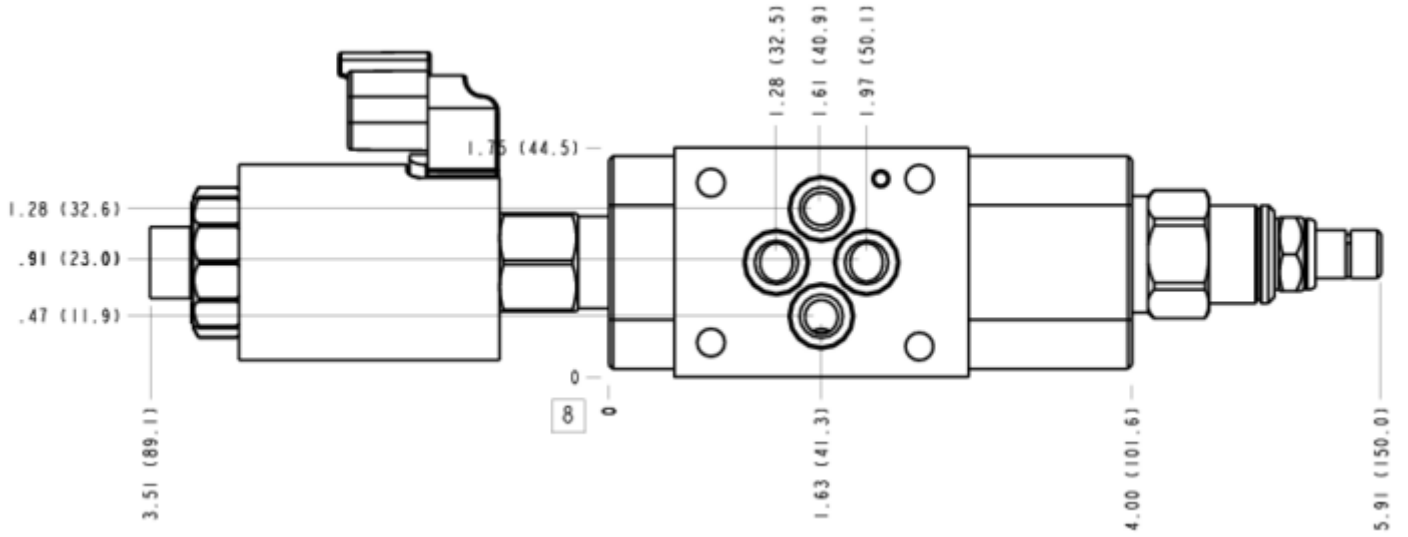

FACE 10

