

CONFIGURATION

L	Control	Standard Screw Adjustment
A	Adjustment Range	500 - 3000 psi (35 - 210 bar), 1000 psi (70 bar) Standard Setting
N	Seal Material	Buna-N
A	Primary Cartridge	A (with RDHA primary cartridge, Direct-acting relief valve)
5	Port and Material Designation	Ports 1 & 2 — 1-1/4" C62; Port T — SAE 12; Gage Ports — SAE 6; Mtg Holes — .375 - 16UNC x .75 DP; Aluminum

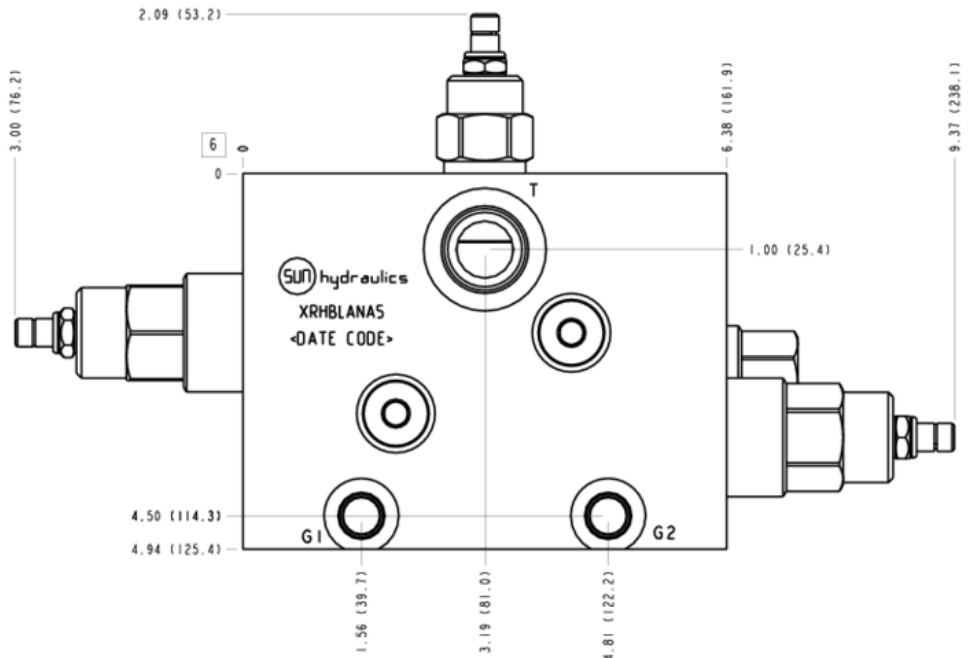

This valve assembly provides high pressure cross-port relief protection and a flushing circuit for hydrostatic transmissions. The hot oil flushing circuit allows a discharge of oil from the low pressure side of the loop. The charge pump replaces the hot, dirty oil with cool, filtered oil. The hot oil discharge is often passed through the cases of the pump and the motor, flushing hot, dirty oil from them as well.

TECHNICAL DATA

NOTE: DATA MAY VARY BY CONFIGURATION. SEE CONFIGURATION SECTION.

Body Type	Line mount
Capacity	40 gpm
Mounting Hole Quantity	4

- NOTES:**
- **Important:** Carefully consider the maximum system pressure. The pressure rating of the manifold is dependent on the manifold material, with the port type/size a secondary consideration. Manifolds constructed of aluminum are not rated for pressures higher than 3000 psi (210 bar), regardless of the port type/size specified.
 - For detailed information regarding the cartridges contained in this assembly, click on the models codes shown in the Included Components tab.

OPTION SELECTION EXAMPLE: XRHBLANA5

CONTROL	(L) ADJUSTMENT RANGE	(A) SEAL MATERIAL	(N)
L Standard Screw Adjustment	A 500 - 3000 psi (35 - 210 bar), 1000 psi (70 bar) Standard Setting B 300 - 1500 psi (20 - 105 bar), 1000 psi (70 bar) Standard Setting C 1000 - 6000 psi (70 - 420 bar), 1000 psi (70 bar) Standard Setting D 200 - 800 psi (14 - 55 bar), 400 psi (28 bar) Standard Setting E 100 - 400 psi (7 - 28 bar), 200 psi (14 bar) Standard Setting S 50 - 200 psi (3,5 - 14 bar), 100 psi (7 bar) Standard Setting W 800 - 4500 psi (55 - 315 bar), 1000 psi (70 bar) Standard Setting	N Buna-N V Viton	

PRIMARY CARTRIDGE	(A)
A A (with RDHA primary cartridge, Direct-acting relief valve)	

INCLUDED COMPONENTS

Part	Description	Quantity
A330-006-008*	SAE Plug	2
DSGXHN	Cartridge	1
RDHALAN	Cartridge - Primary	2
RPGCLNN	Cartridge	1

TECHNICAL FEATURES

- A unique feature of the hot oil shuttle is that the setting of the hot oil relief can be confirmed or adjusted when the transmission is in neutral.
- The two ports marked 1 are common as are the two marked 2. Therefore the assembly can be teed off the loop rather than being plumbed into the loop.
- The two ports marked 1 are common as are the two marked 2. The high pressure relief that is physically on the same side as port 1 controls the pressure on port 2 and vice versa.
- When the transmission is in neutral the charge pressure is controlled by the charge pump relief. When the hot oil shuttle opens, some or all of the charge pump flow is redirected to the hot oil relief. The charge pump relief must be set higher than the hot oil relief to produce hot oil flow. The higher the differential pressure between the 2 reliefs, the higher the hot oil flow. The amount of hot oil flow is determined by the pressure vrs flow curves of the 2 reliefs and is difficult to quantify.
- The standard setting of the hot oil relief is 200 psi (14 bar) at a flow of 4 gpm (16 L/min).
- Hydraulic motors leak. Therefore a mechanical brake is recommended to positively lock any stopped live load.

PERFORMANCE CURVES

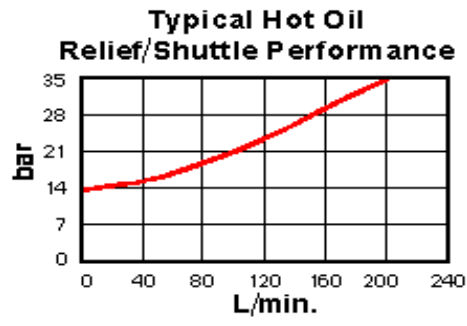
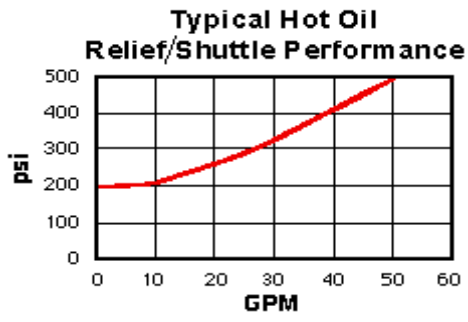

MANIFOLD FACES

FACE GRID

1	2	3	4
5	6	7	8
9	10	11	12

FACE 2

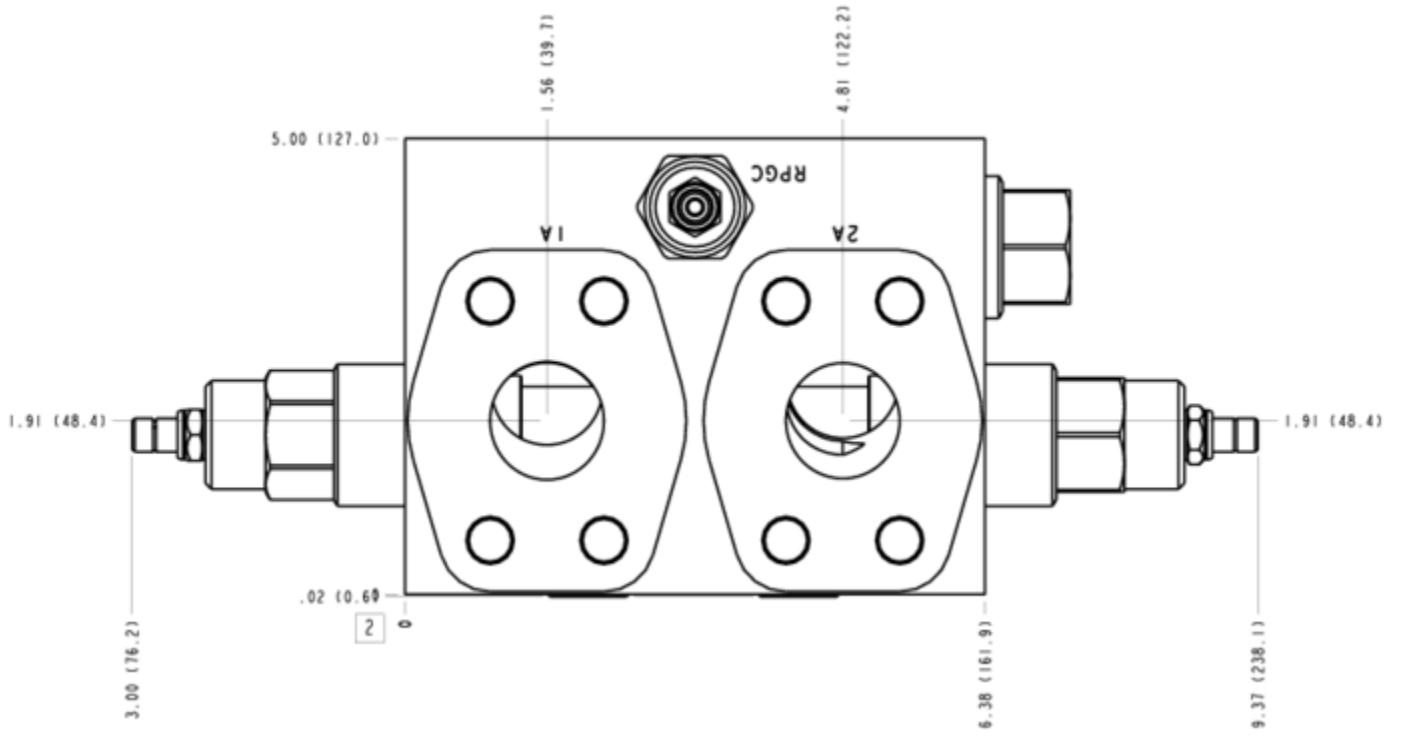

FACE 5

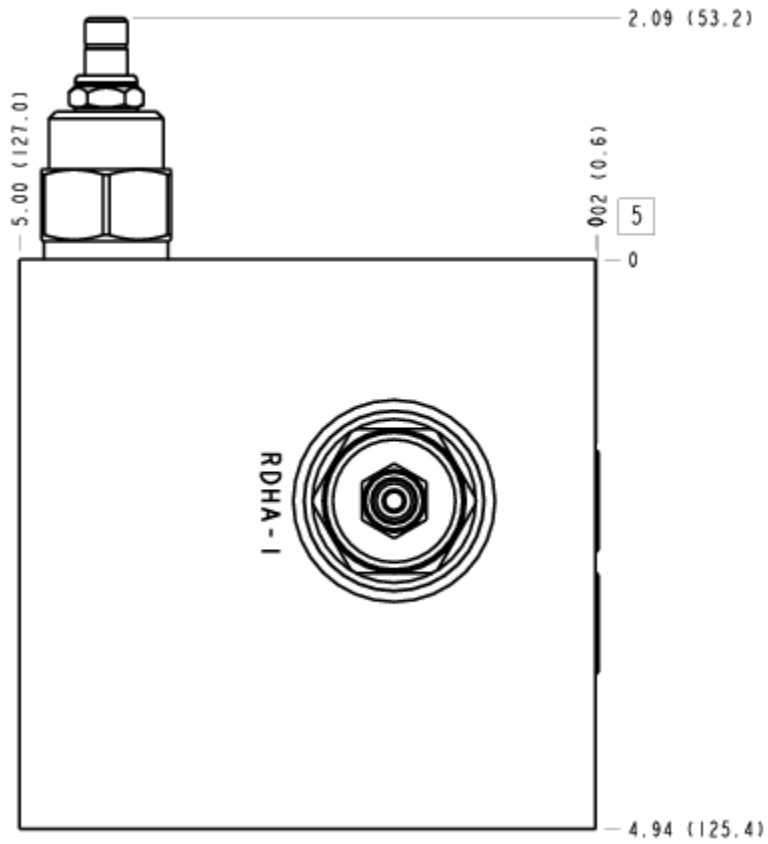

FACE 6

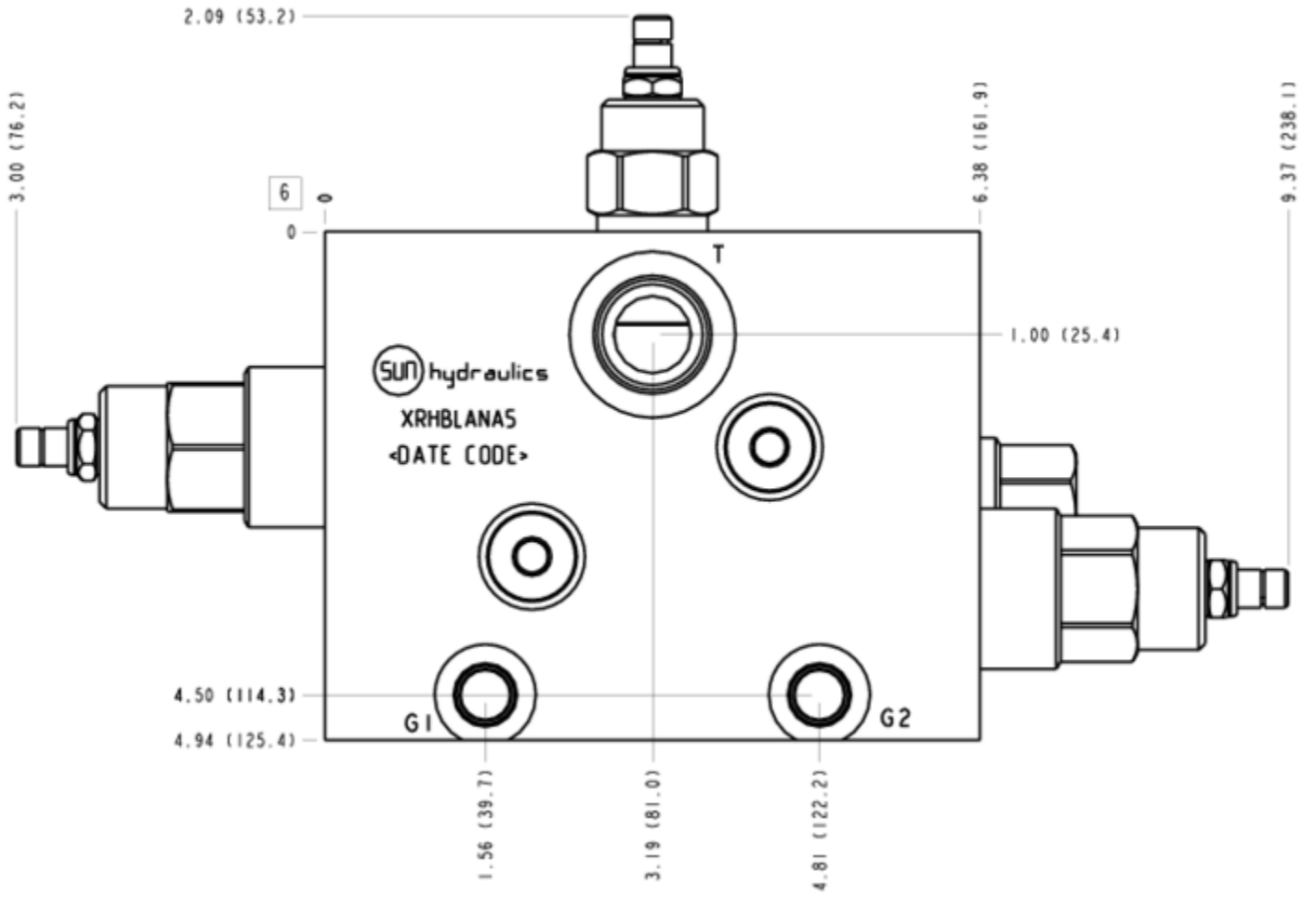

FACE 7

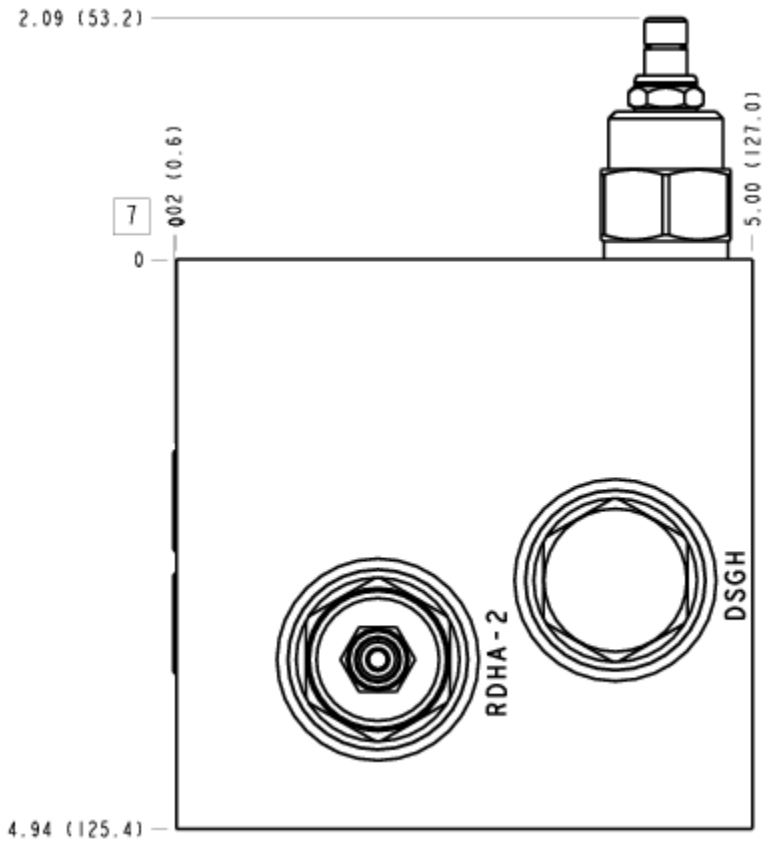

FACE 8



FACE 10

