

## CONFIGURATION

<b>L</b> Control	Standard Screw Adjustment
<b>A</b> Adjustment Range	500 - 3000 psi (35 - 210 bar), 1000 psi (70 bar) Standard Setting
<b>N</b> Seal Material	Buna-N
<b>A</b> Primary Cartridge	A (with RDJA primary cartridge, Acción-directa alivio válvula)
<b>Port and</b>	Ports 1 & 2 — 1 1/2" Code 62 ;
<b>6</b> Material Designation	Port T — SAE 16; Gage Ports — SAE 6; Mtg Holes — .375 - 16UNC x .88 DP; Aluminum

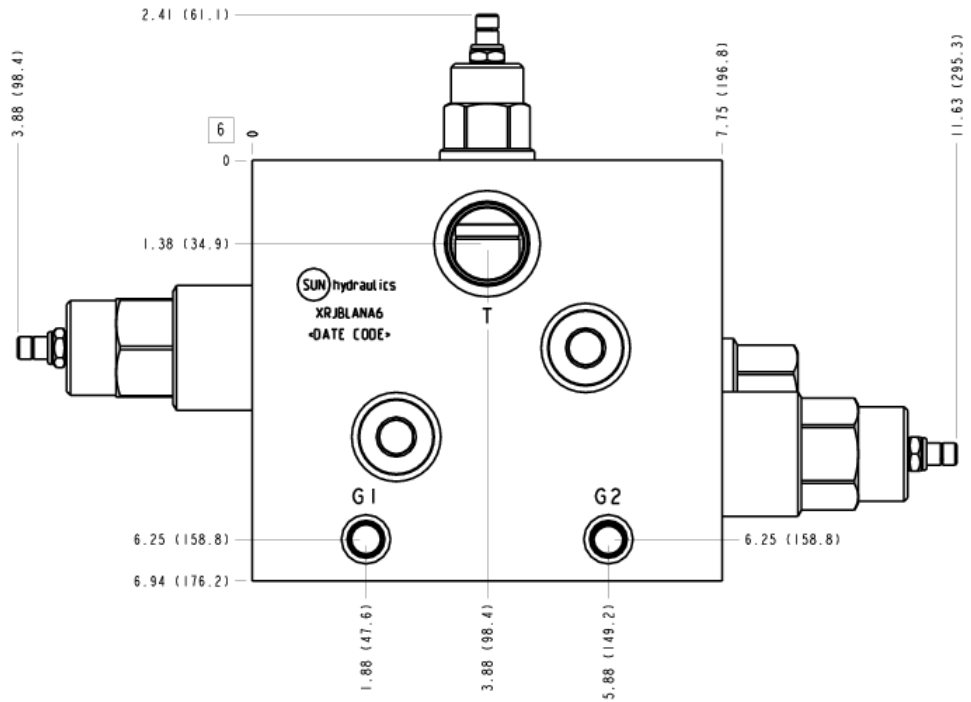

## TECHNICAL DATA

NOTE: DATA MAY VARY BY CONFIGURATION. SEE CONFIGURATION SECTION.

Body Type	montaje en línea
Capacity	480 L/min.
Mounting Hole Quantity	4

**OPTION SELECTION EXAMPLE: XRJBLANA6**

CONTROL	(L) ADJUSTMENT RANGE	(A) SEAL MATERIAL	(N)
<b>L</b> Standard Screw Adjustment	<b>A</b> 500 - 3000 psi (35 - 210 bar), 1000 psi (70 bar) Standard Setting	<b>N</b> Buna-N	
<b>C</b> Tamper Resistant - Factory Set	<b>C</b> 1000 - 6000 psi (70 - 420 bar), 1000 psi (70 bar) Standard Setting	<b>V</b> Viton	
	<b>D</b> 200 - 800 psi (14 - 55 bar), 400 psi (28 bar) Standard Setting		
	<b>E</b> 100 - 400 psi (7 - 28 bar), 200 psi (14 bar) Standard Setting		
	<b>S</b> 50 - 200 psi (3,5 - 14 bar), 100 psi (7 bar) Standard Setting		
	<b>W</b> 800 - 4500 psi (55 - 315 bar), 1000 psi (70 bar) Standard Setting		

PRIMARY CARTRIDGE (A)

<b>A</b> A (with RDJA primary cartridge, Acción-directa alivio válvula )
--

**INCLUDED COMPONENTS**

Part	Description	Quantity
A330-006-012*	SAE Plug	2
DSIHXHN	Cartridge	1
RDJALAN	Cartridge - Primary	2
RPICLNN	Cartridge	1

**PERFORMANCE CURVES**

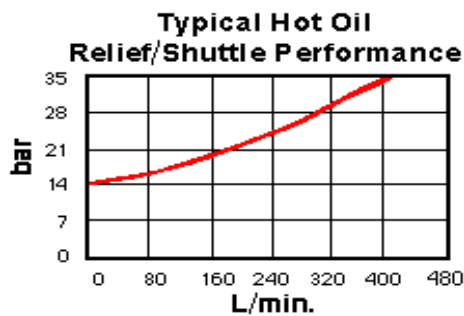
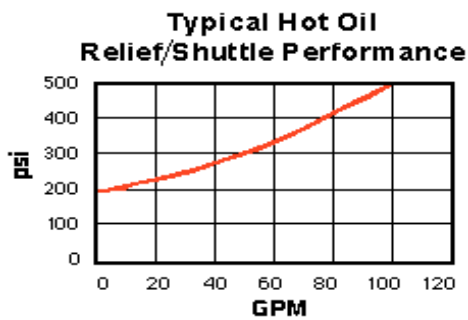

# MANIFOLD FACES

## FACE GRID

1	2	3	4
5	6	7	8
9	10	11	12

## FACE 2

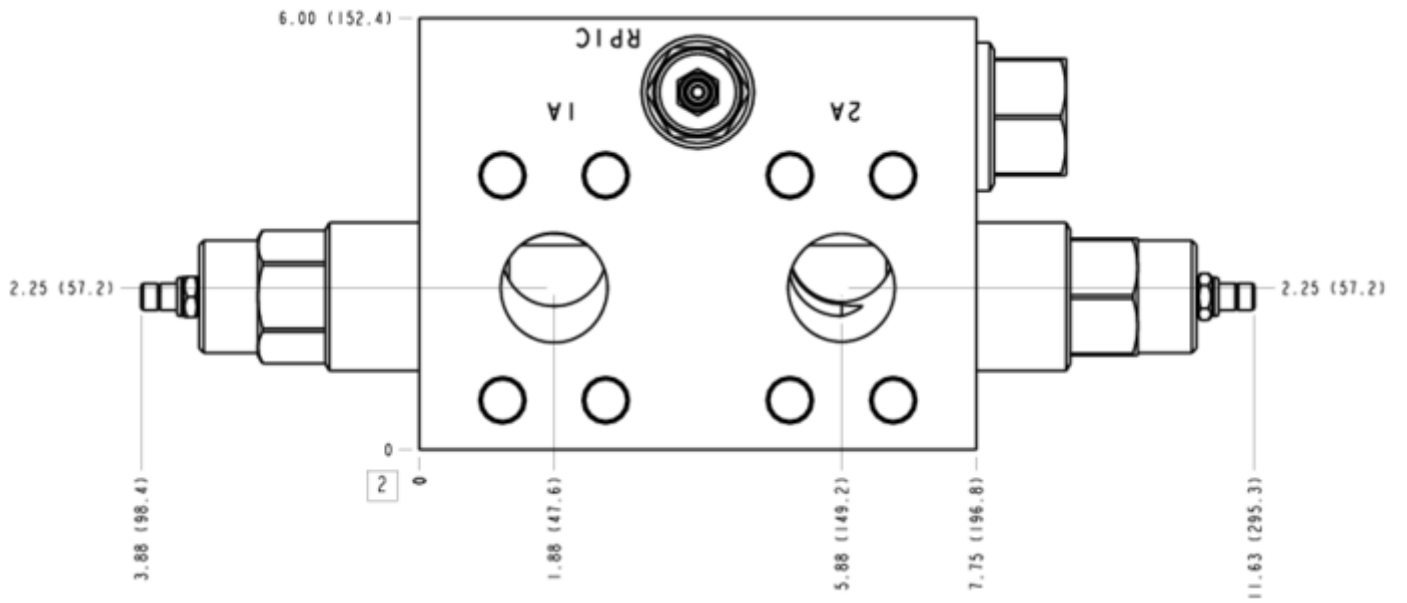

FACE 5

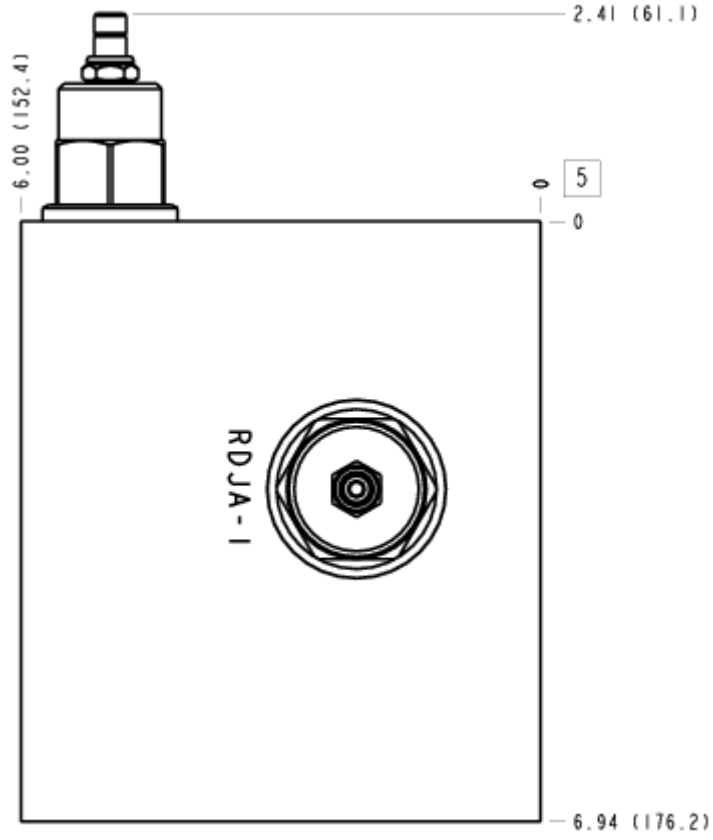

FACE 6

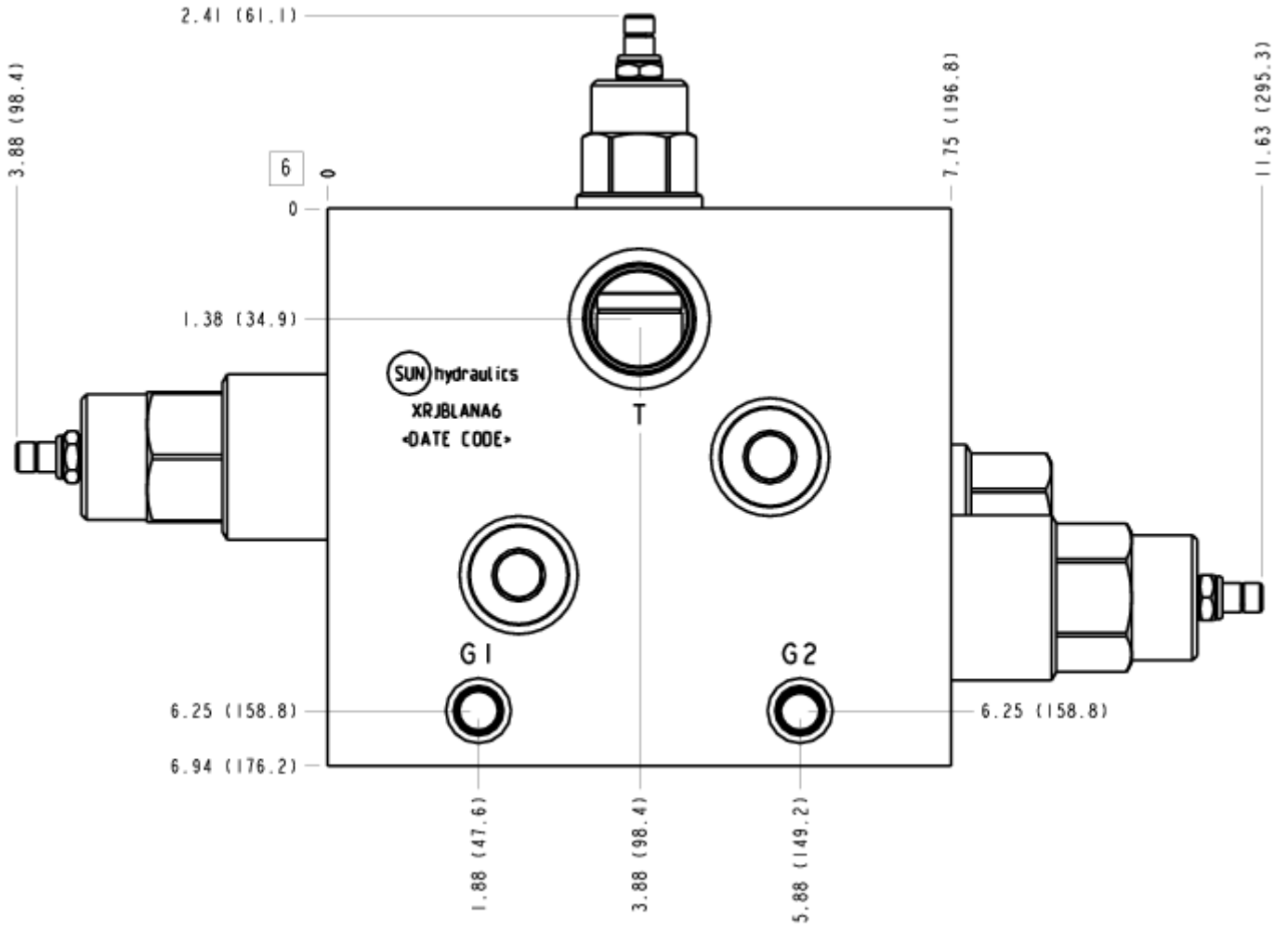

FACE 7

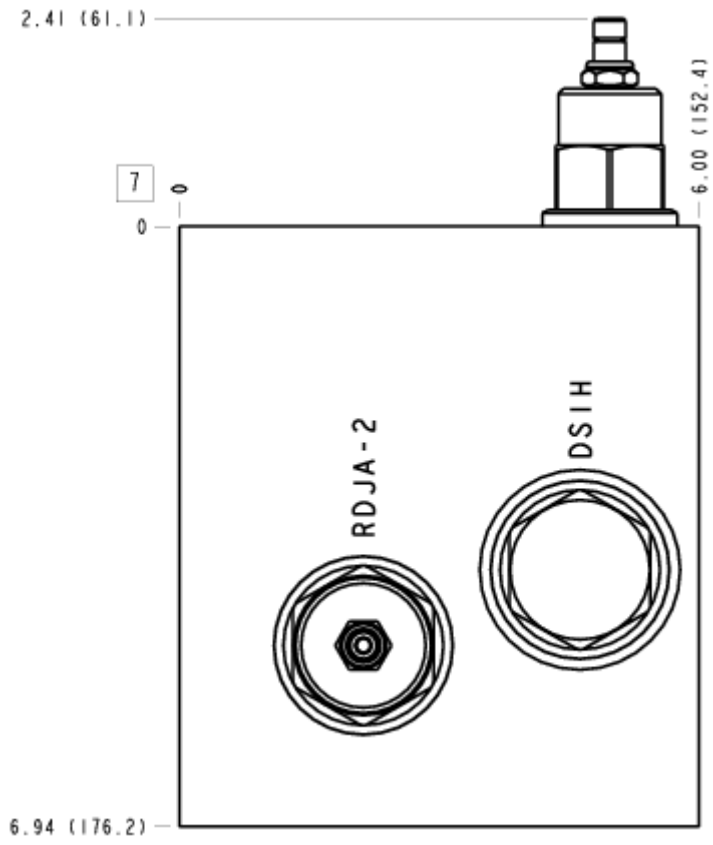

FACE 8

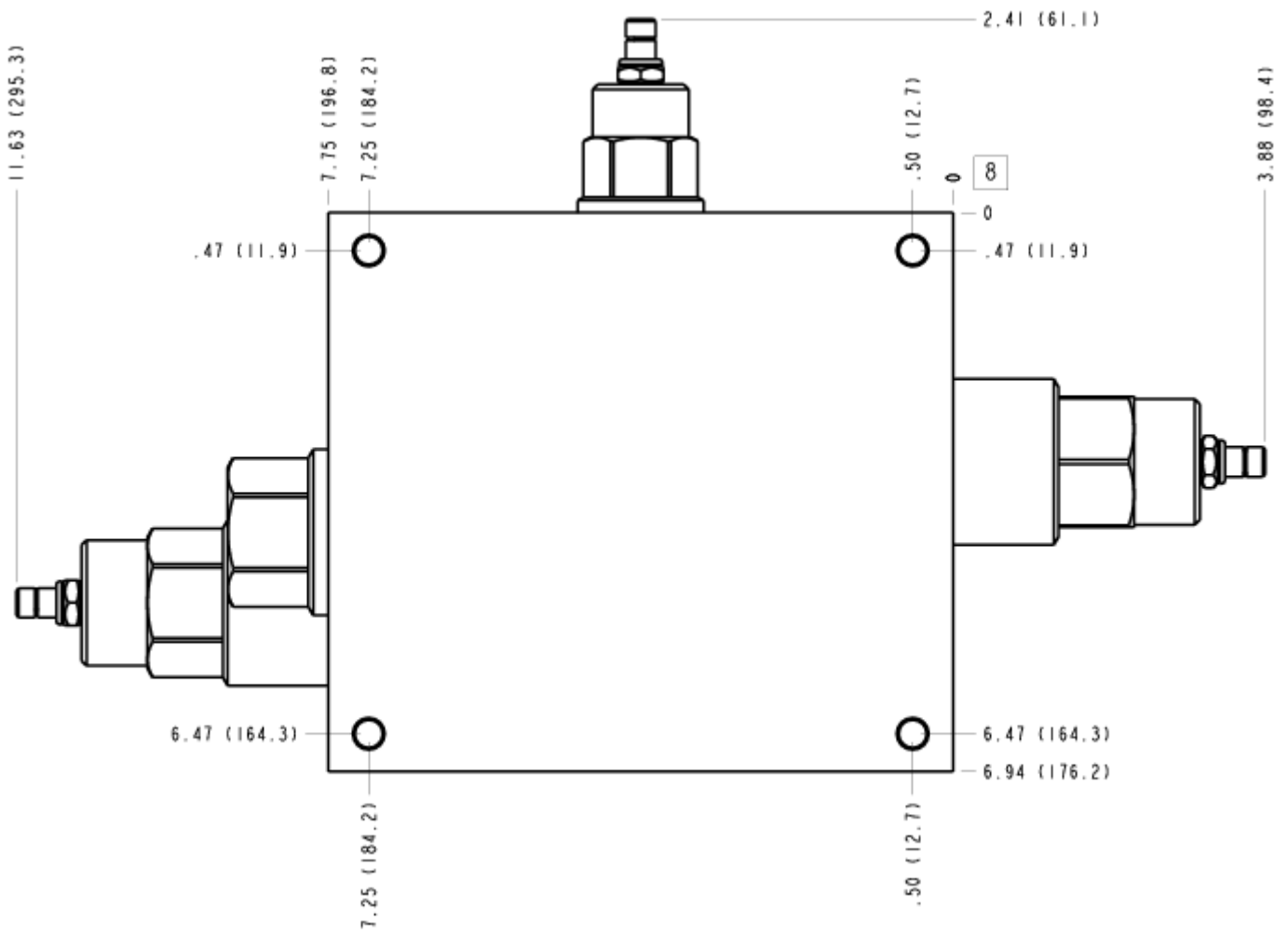

FACE 10

