

TECHNICAL DATA NOTE: DATA MAY VARY BY CONFIGURATION. SEE CONFIGURATION SECTION.

	60 L/min.
	8.6 mm
	Through
	2

OPTION SELECTION EXAMPLE: YCCNLHNAK

(L)	(H)	(N)
L	H 1000 - 4000 psi 25 psi (70 - 280 bar 1.), 3000 psi (210 bar)	N
	A 1000 - 4000 psi 4 psi (70 - 280 bar 0.3 bar), 3000 psi (210 bar)	V
	B 400 - 1500 psi 4 psi (28 - 105 bar 0.3 bar), 1000 psi (70 bar)	

PRIMARY CARTRIDGE

(A)

A	3:1 (with CBCA primary cartridge, 3:1,)
H	10:1 (with CBCHX primary cartridge, , 10:1,)
G	4.5:1 (with CBCGX primary cartridge, , 4.5:1,)
A	3:1 (with CBCAX primary cartridge, , 3:1,)
H	10:1 (with CBCH primary cartridge, 10:1,)
G	4.5:1 (with CBCG primary cartridge, 4.5:1,)

INCLUDED COMPONENTS

Part	Description	Quantity
CBCALHN	Cartridge - Primary	2
CXCDXCN	Cartridge	2

MANIFOLD FACES

FACE GRID

1	2	3	4
5	6	7	8
9	10	11	12

FACE 2

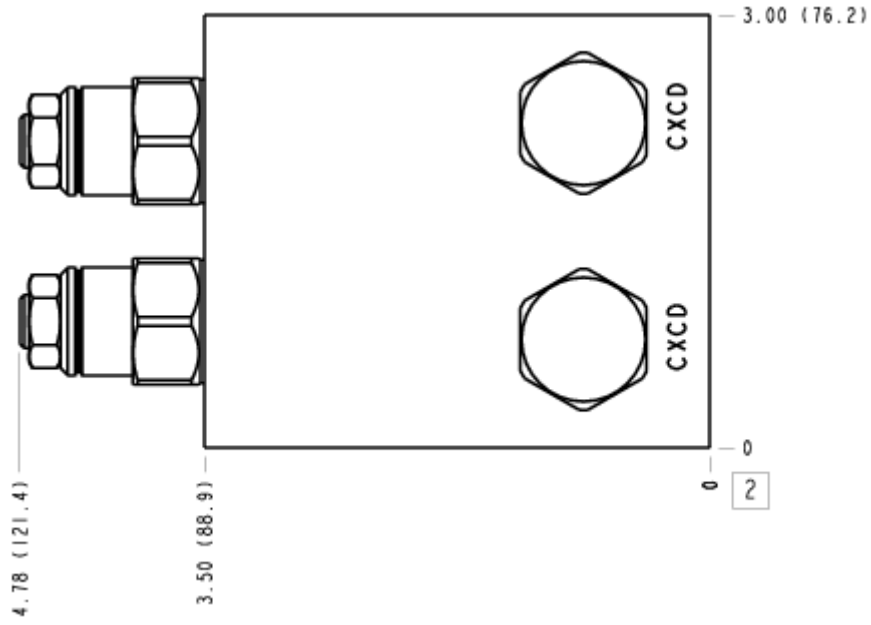

FACE 5

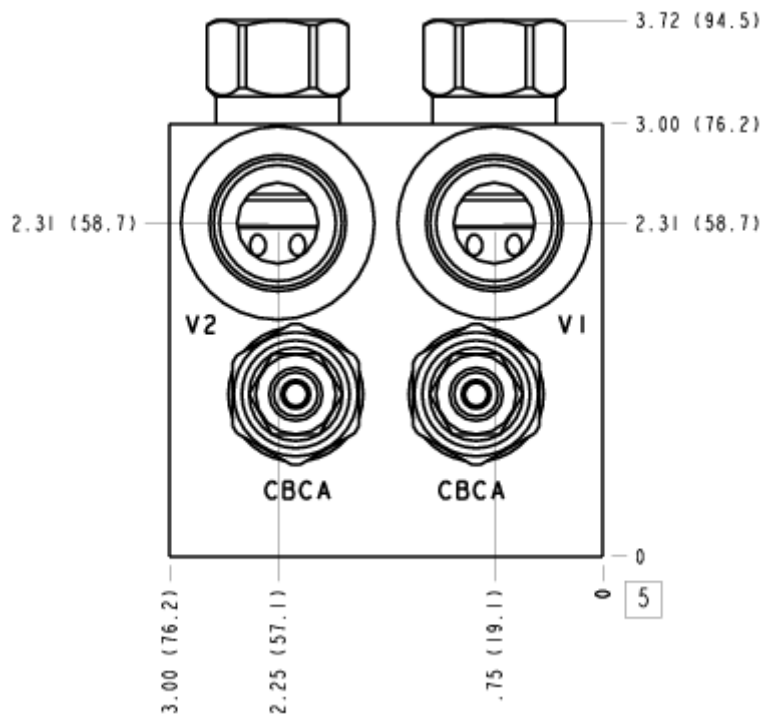

FACE 6

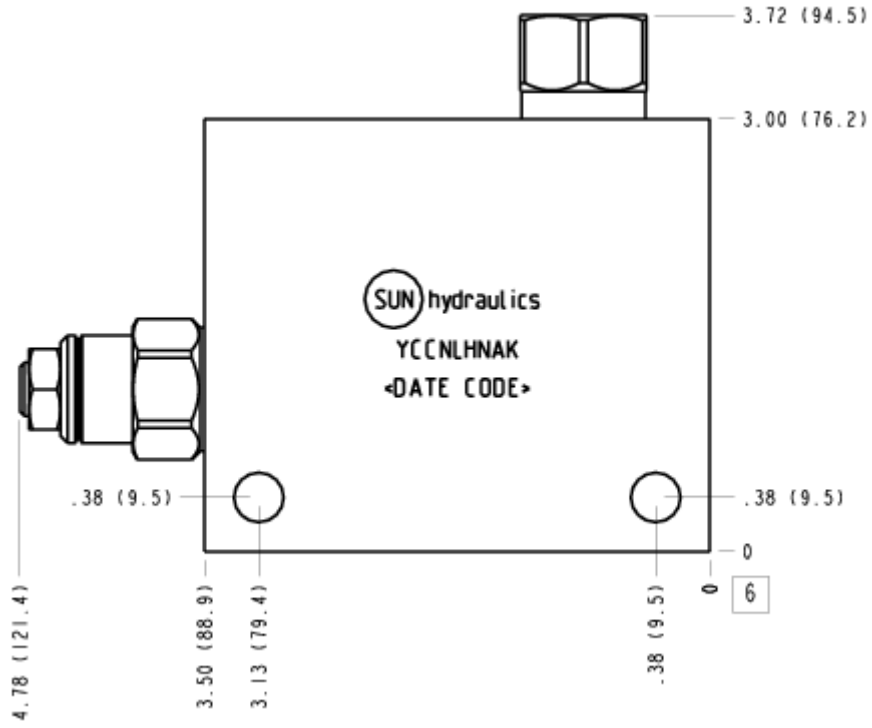

FACE 7

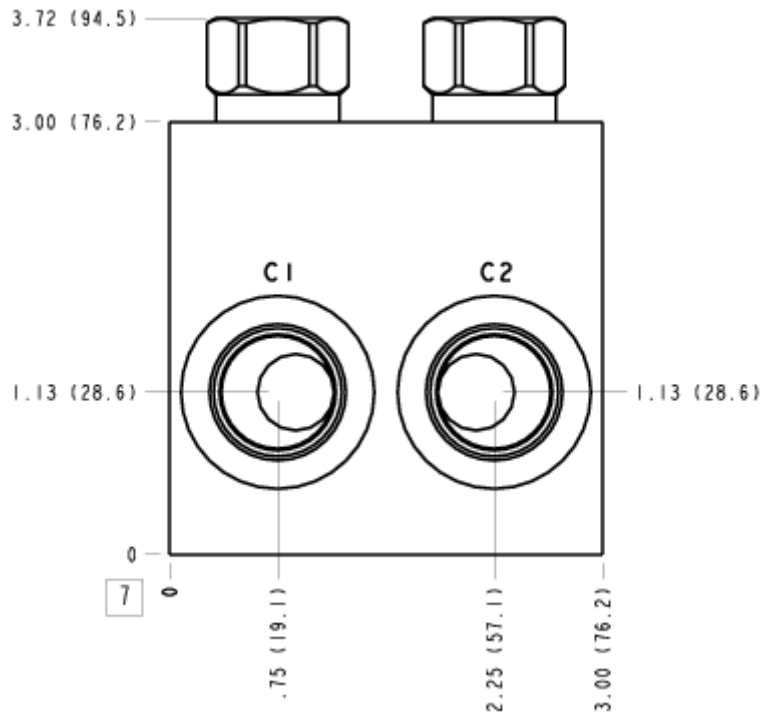

FACE 8

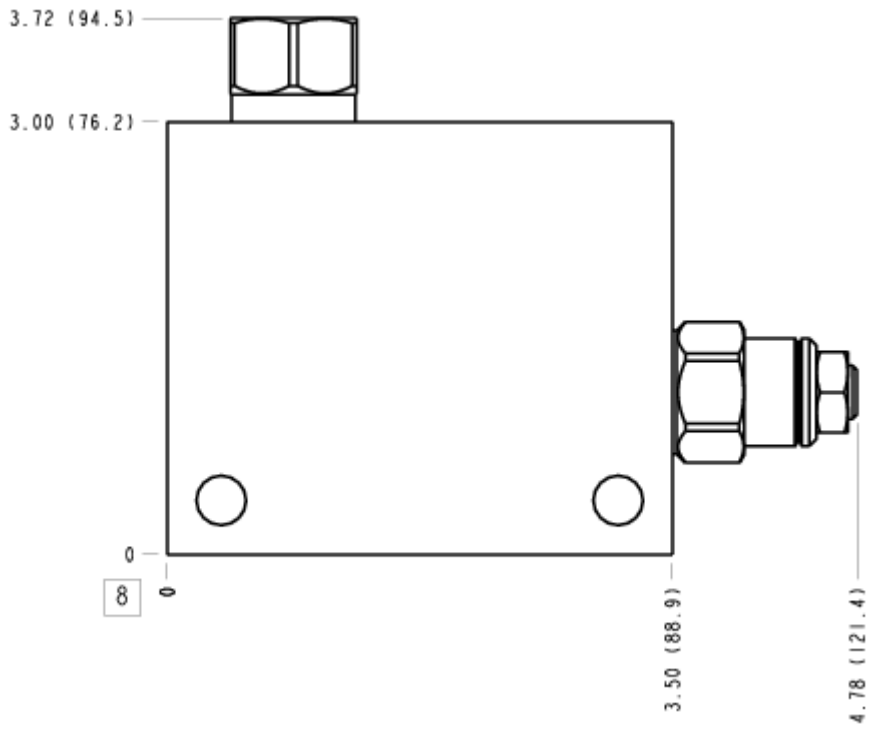

FACE 10

