



sunhydraulics.com/model/YCCP

This valve assembly provides overrunning load-control, load-port relief protection, supplies make-up oil, and flushes hot dirty oil out of the actuator. All oil coming out of the actuator returns to tank through port T.

TECHNICAL DATA

Body Type	Line mount
Mounting Hole Diameter	.34 in.
Mounting Hole Depth	Through
Mounting Hole Quantity	2

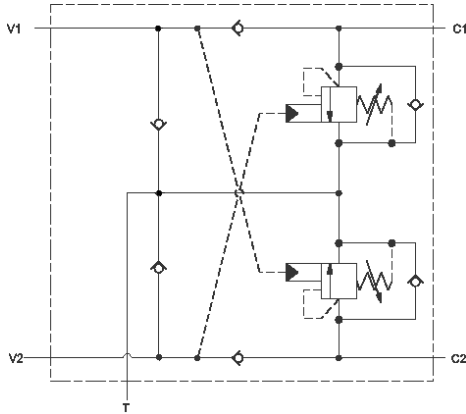

CONFIGURATION

NOTES:

L Control	Standard Screw Adjustment
H Functional Setting Range	1000 - 4000 psi w/25 psi Check (70 - 280 bar w/ 1,7 bar Check), 3000 psi (210 bar) Standard Setting
N Seal Material	Buna-N
A Pilot Ratio (4th Letter) of Primary Cartridge	3:1 (with CBCA primary cartridge, 3:1 pilot ratio, standard capacity counterbalance valve)
Port and Material Designation	

- **Important:** Carefully consider the maximum system pressure. The pressure rating of the manifold is dependent on the manifold material, with the port type/size a secondary consideration. Manifolds constructed of aluminum are not rated for pressures higher than 3000 psi (210 bar), regardless of the port type/size specified.
- For detailed information regarding the cartridges contained in this assembly, click on the models codes shown in the Included Components tab.

CONFIGURATION OPTIONS

Model Code Example: YCCPLHNA

CONTROL	(L) FUNCTIONAL SETTING RANGE	(H) SEAL MATERIAL	(N)
L Standard Screw Adjustment	H 1000 - 4000 psi w/25 psi Check (70 - 280 bar w/ 1,7 bar Check), 3000 psi (210 bar) Standard Setting A 1000 - 4000 psi w/4 psi Check (70 - 280 bar w/ 0,3 bar Check), 3000 psi (210 bar) Standard Setting B 400 - 1500 psi w/4 psi Check (28 - 105 bar w/ 0,3 bar Check), 1000 psi (70 bar) Standard Setting I 400 - 1500 psi w/25 psi Check (28 - 105 bar w/ 1,7 bar Check), 1000 psi (70 bar) Standard Setting	N Buna-N V Viton	

PRIMARY CARTRIDGE

(A)

A	3:1 (with CBCA primary cartridge, 3:1 pilot ratio, standard capacity counterbalance valve)
Y	2:1 (with CBCYX primary cartridge, Fixed setting, 2:1 pilot ratio, standard capacity counterbalance valve)
H	10:1 (with CBCHX primary cartridge, Fixed setting, 10:1 pilot ratio, standard capacity counterbalance valve)
G	4.5:1 (with CBCGX primary cartridge, Fixed setting, 4.5:1 pilot ratio, standard capacity counterbalance valve)
A	3:1 (with CBCAX primary cartridge, Fixed setting, 3:1 pilot ratio, standard capacity counterbalance valve)
Y	2:1 (with CBCY primary cartridge, 2:1 pilot ratio, standard capacity counterbalance valve)
H	10:1 (with CBCH primary cartridge, 10:1 pilot ratio, standard capacity counterbalance valve)
G	4.5:1 (with CBCG primary cartridge, 4.5:1 pilot ratio, standard capacity counterbalance valve)