

**CONFIGURATION**

X Control	Not Adjustable
C Cracking Pressure	30 psi (2 bar)
N Seal Material	Buna-N
A Primary Cartridge	A (with CXFA primary cartridge, Caudal libre de nariz al lado anti-retorno válvula )
L Port and Material Designation	Ports P, T, A1, A2 — SAE 12; Aluminum

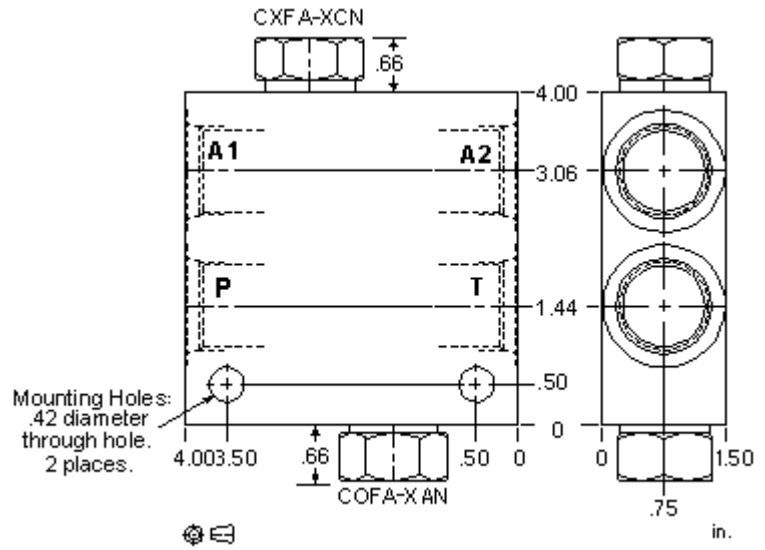

**TECHNICAL DATA**

TECHNICAL DATA		NOTE:
Body Type	montaje en línea	DATA
Capacity	160 L/min.	MAY
Mounting Hole Diameter	10,4 mm	VARY
Mounting Hole Depth	Through	BY
Mounting Hole Quantity	2	

CONFIGURATION. SEE CONFIGURATION SECTION.

**OPTION SELECTION EXAMPLE: YCFEXCNAL**

CONTROL	(X) CRACKING PRESSURE	(C) SEAL MATERIAL	(N)
<b>X</b> Not Adjustable	<b>C</b> 30 psi (2 bar)	<b>N</b> Buna-N	
	F 100 psi (7 bar)	V Viton	
	Z 1 psi (0,07 bar)		

PRIMARY CARTRIDGE (A)

<b>A</b> A (with CXFA primary cartridge, Caudal libre de nariz al lado anti-retorno válvula )
---

**INCLUDED COMPONENTS**

Part	Description	Quantity
COFAXAN	Cartridge	1
CXFAXCN	Cartridge - Primary	1

**MANIFOLD FACES**

**FACE GRID**

1	2	3	4
5	6	7	8
9	10	11	12

**FACE 2**

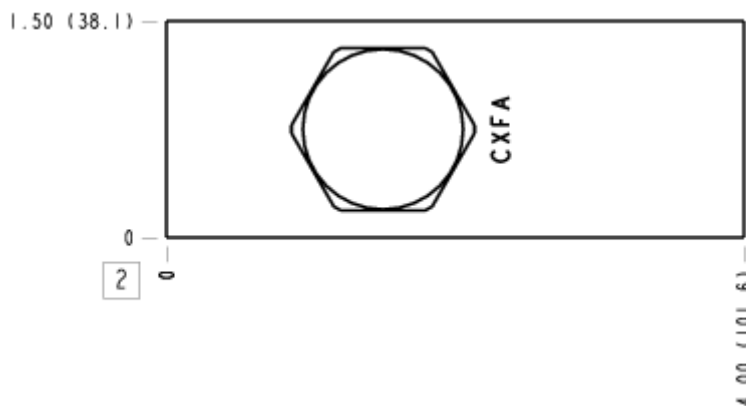

# FACE 5

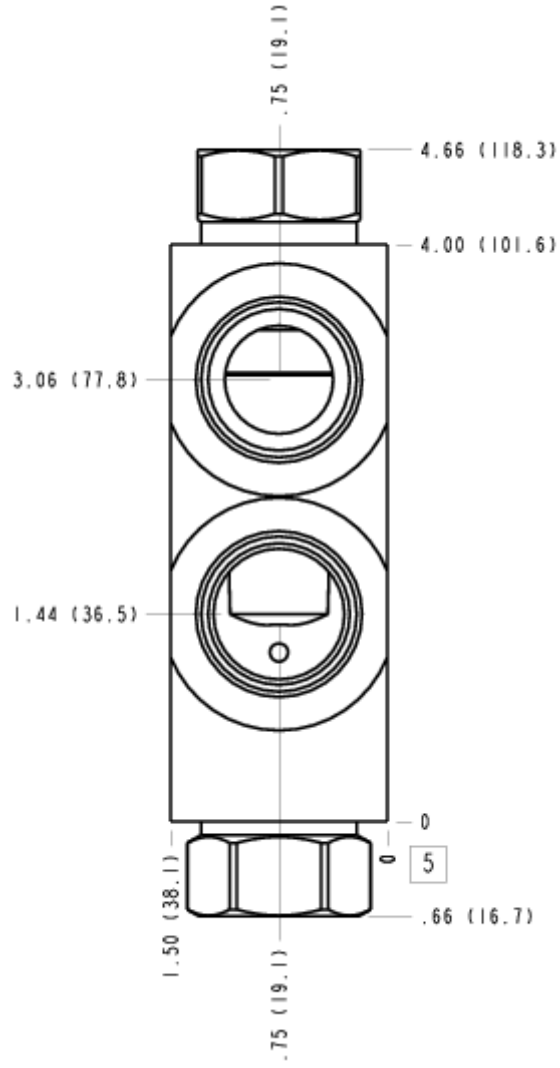

FACE 6

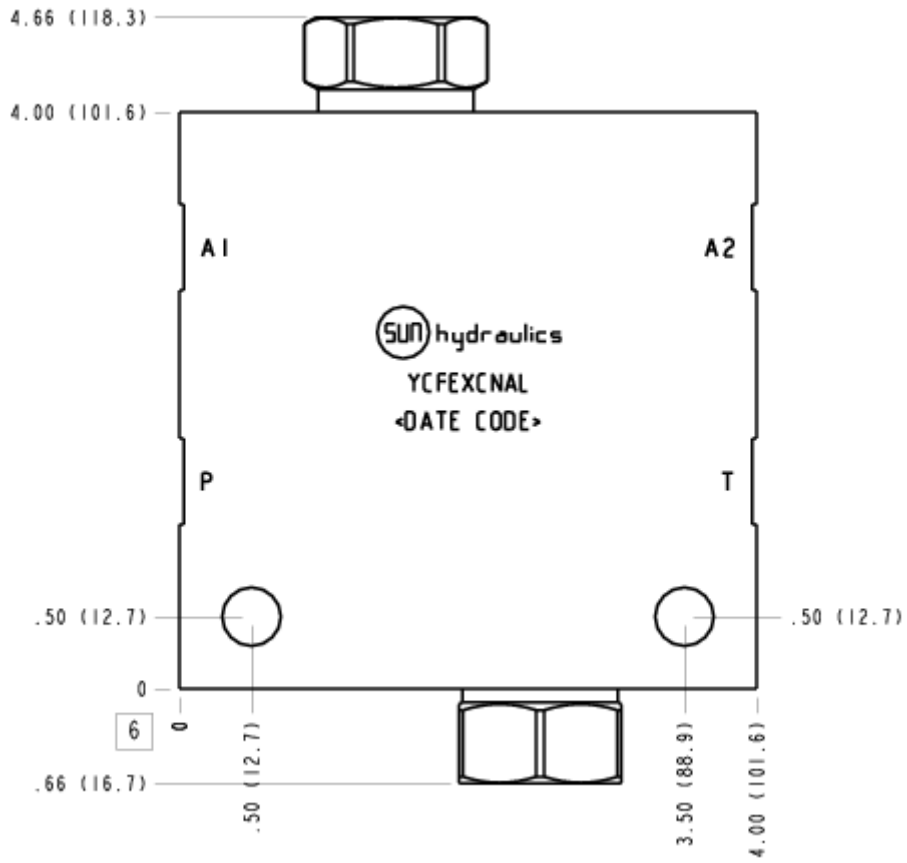

# FACE 7

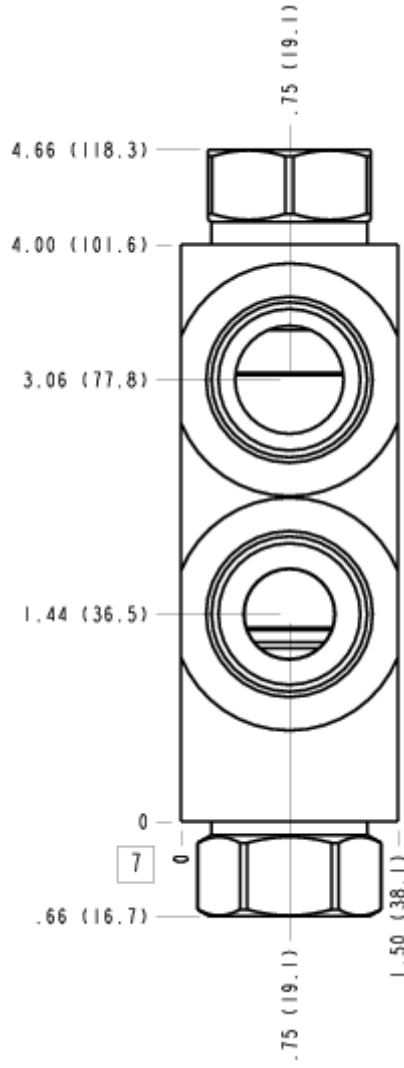

FACE 8

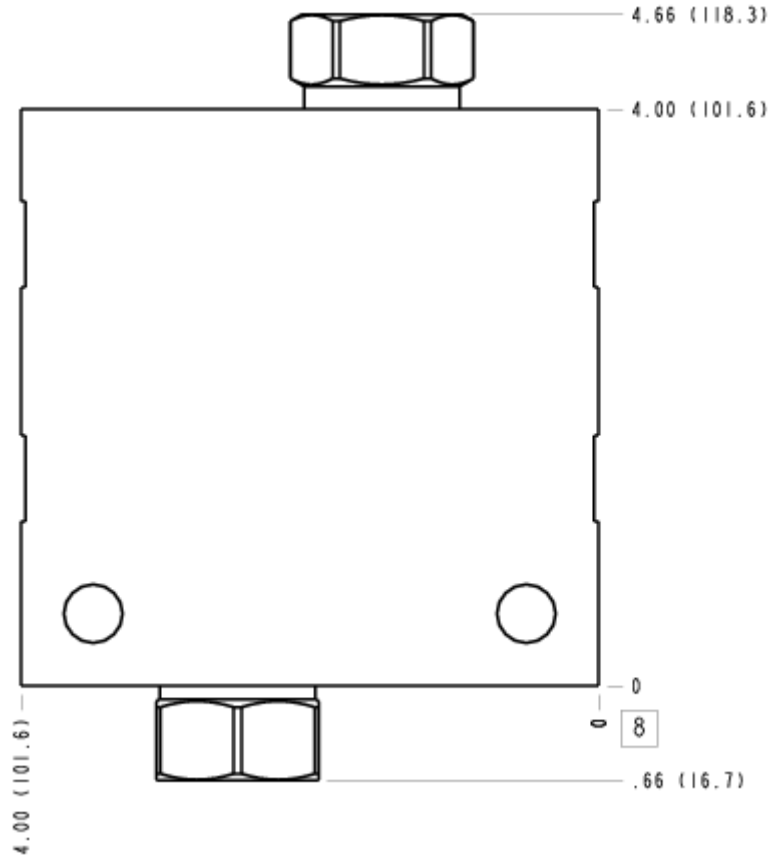

FACE 10

