

This valve assembly provides overrunning load-control, load-port relief protection, supplies make-up oil, and flushes hot dirty oil out of the actuator and includes a load sense shuttle for brake release. All oil coming out of the actuator returns to tank through port T.

TECHNICAL DATA NOTE: DATA MAY VARY BY CONFIGURATION. SEE CONFIGURATION SECTION.

Body Type	Line mount
Capacity	60 gpm
Mounting Hole Diameter	.53 in.
Mounting Hole Depth	Through
Mounting Hole Quantity	2

- NOTES:**
- **Important:** Carefully consider the maximum system pressure. The pressure rating of the manifold is dependent on the manifold material, with the port type/size a secondary consideration. Manifolds constructed of aluminum are not rated for pressures higher than 3000 psi (210 bar), regardless of the port type/size specified.
 - For detailed information regarding the cartridges contained in this assembly, click on the models codes shown in the Included Components tab.

OPTION SELECTION EXAMPLE: YCGPLHNAM

CONTROL	(L) FUNCTIONAL SETTING RANGE	(H) SEAL MATERIAL	(N)
L Standard Screw Adjustment	H 1000 - 4000 psi w/25 psi Check (70 - 280 bar w/ 1,7 bar Check), 3000 psi (210 bar) Standard Setting	N Buna-N	
C Tamper Resistant - Factory Set	A 1000 - 4000 psi w/4 psi Check (70 - 280 bar w/ 0,3 bar Check), 3000 psi (210 bar) Standard Setting	V Viton	
	B 400 - 1500 psi w/4 psi Check (28 - 105 bar w/ 0,3 bar Check), 1000 psi (70 bar) Standard Setting		
	I 400 - 1500 psi w/25 psi Check (28 - 105 bar w/ 1,7 bar Check), 1000 psi (70 bar) Standard Setting		

PRIMARY CARTRIDGE (A)

A	3:1 (with CBGA primary cartridge, 3:1 pilot ratio, standard capacity counterbalance valve)
H	10:1 (with CBGH primary cartridge, 10:1 pilot ratio, standard capacity counterbalance valve)
G	4.5:1 (with CBGG primary cartridge, 4.5:1 pilot ratio, standard capacity counterbalance valve)

INCLUDED COMPONENTS

Part	Description	Quantity
CBGALHN	Cartridge - Primary	2
CXGDXAN	Cartridge	2
CXHAXAN	Cartridge	2

MANIFOLD FACES

FACE GRID

1	2	3	4
5	6	7	8
9	10	11	12

FACE 2

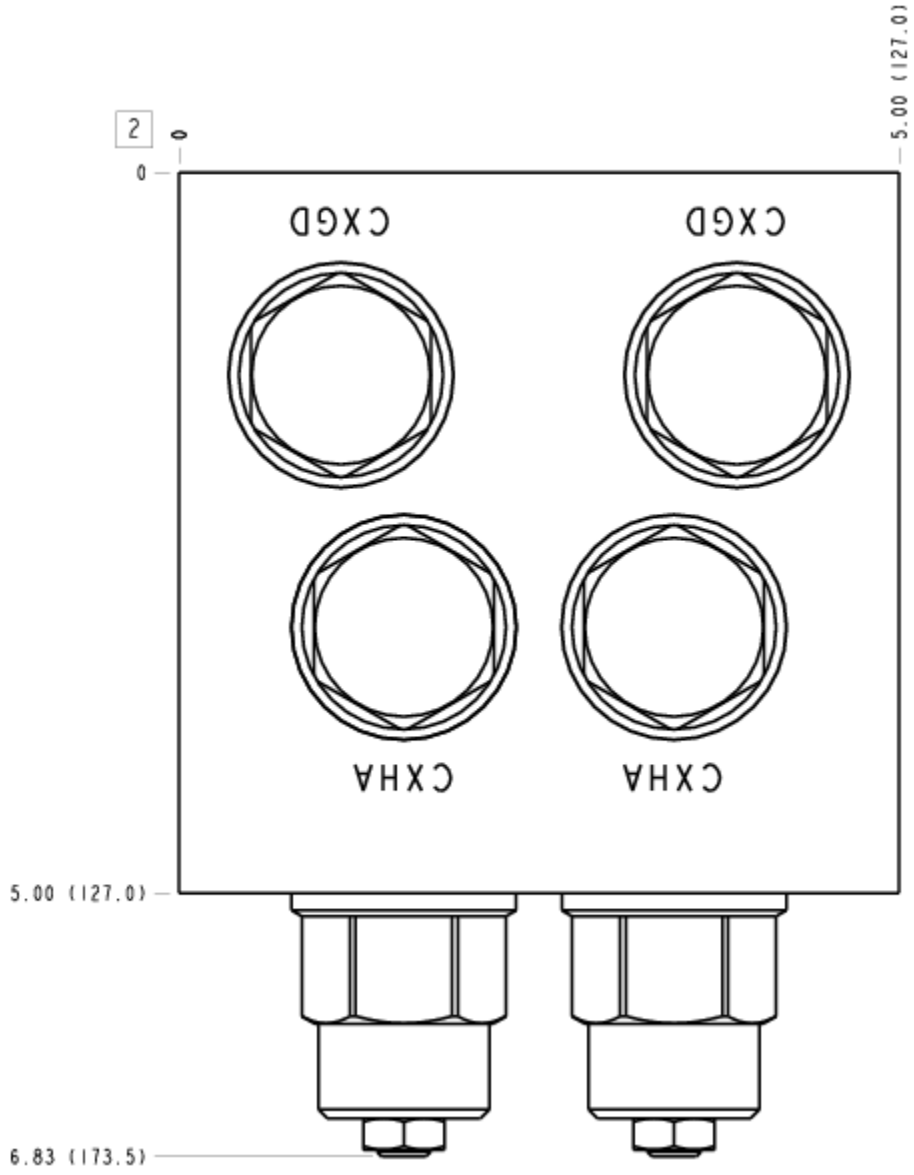

FACE 5

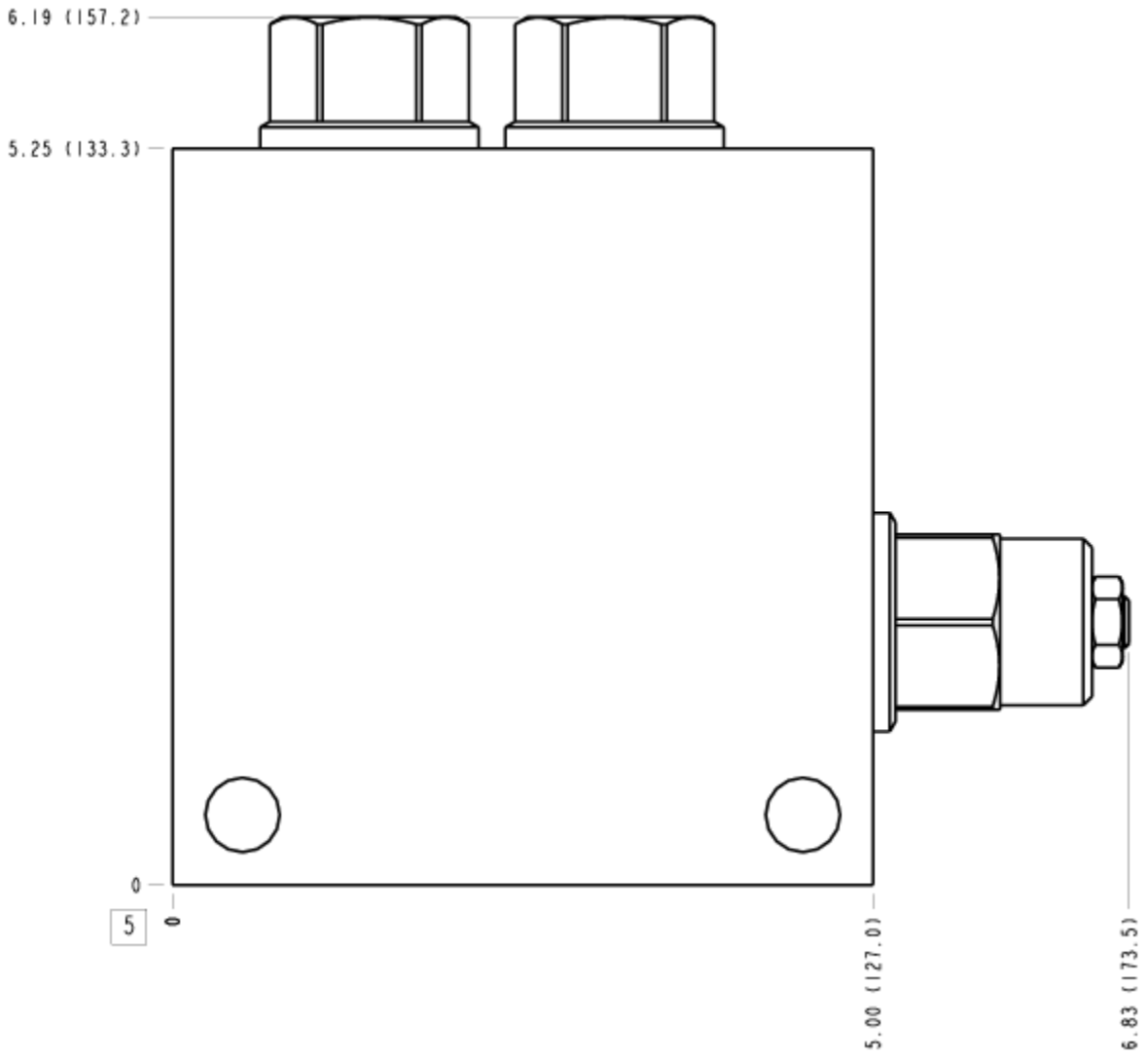

FACE 6

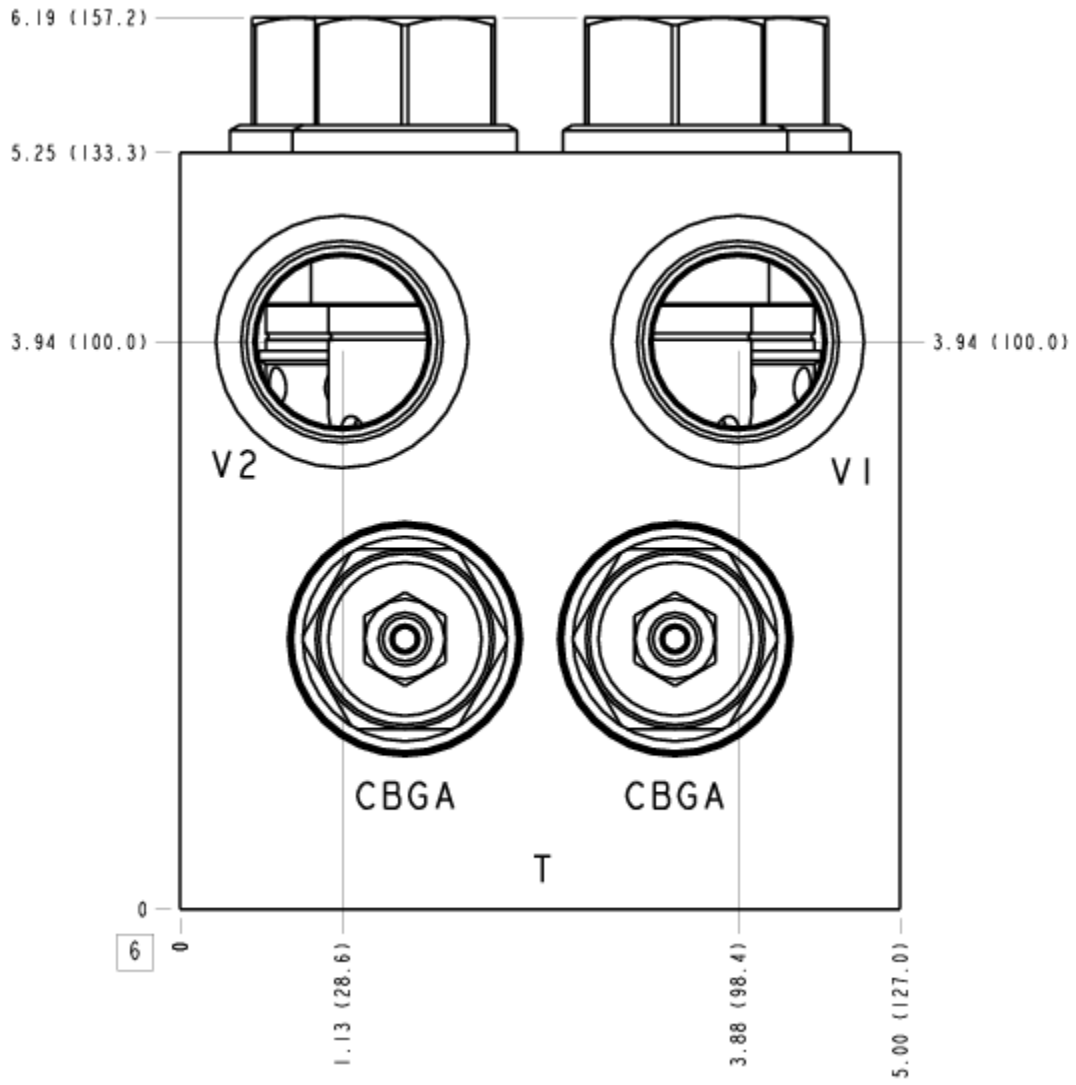

FACE 7

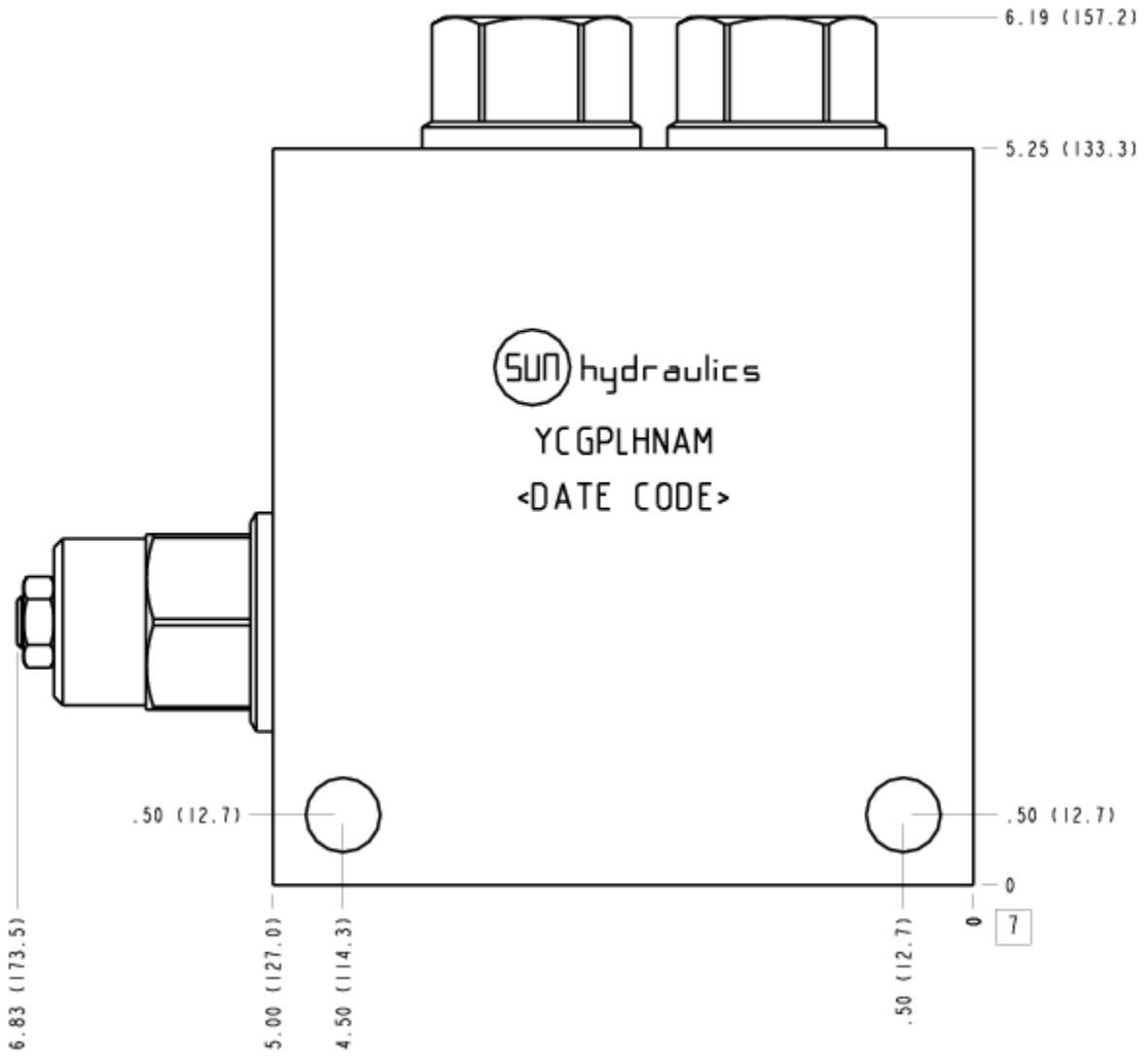

FACE 8

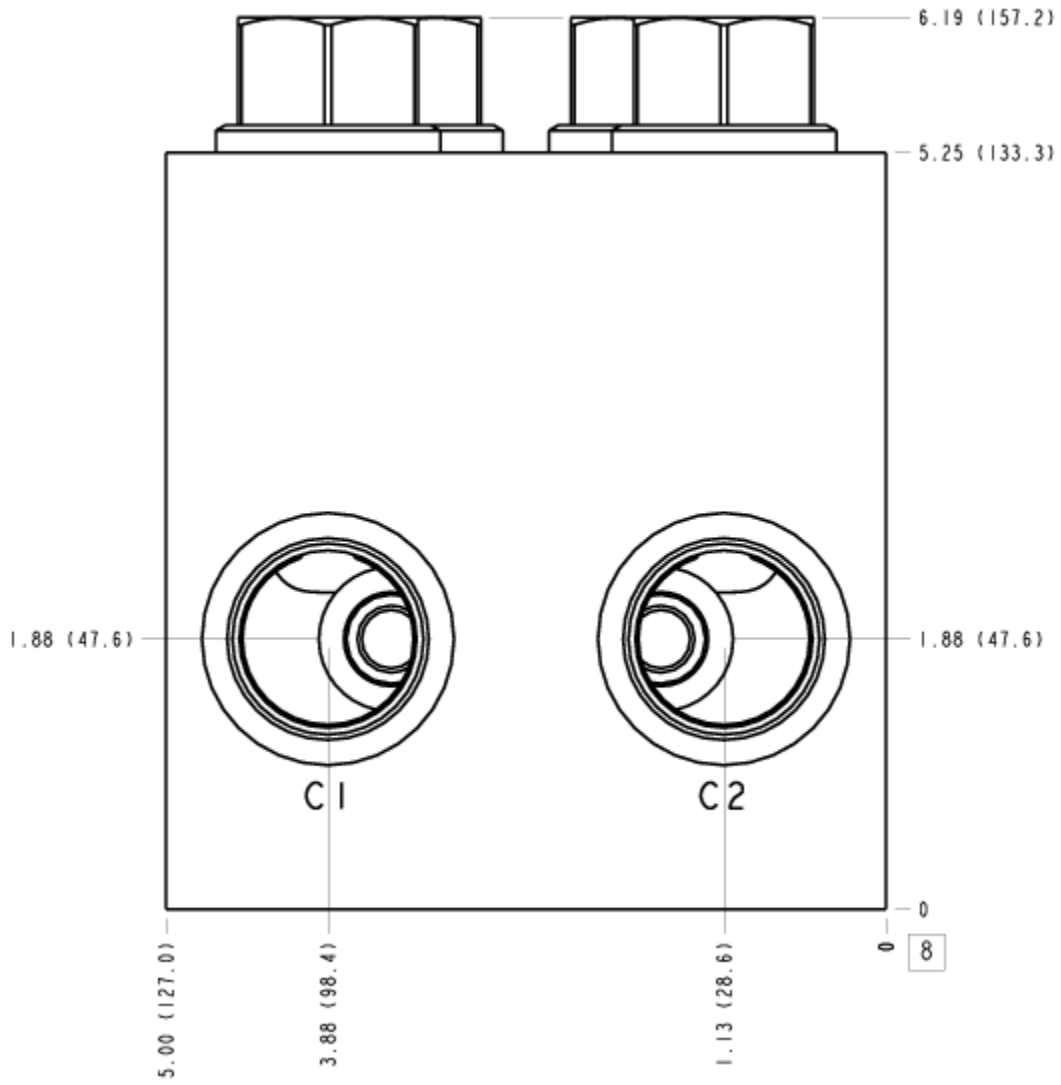

FACE 10

