

The pressure sensitive regenerative valve assembly allows a double-acting, single rod cylinder to be extended more rapidly using the same pump flow. To achieve this, oil from the rod end of the cylinder is added to the pump flow to the blind end, increasing the rate of extension. It incorporates a pressure adjustable, counterbalance valve that provides a smooth transition when the load is engaged and pressure in the blind end rises to approximately 25% of the set point of the counterbalance valve, at which time the regenerative flow decreases smoothly until rod end flow is fully diverted to tank. Full pump pressure is then applied to the blind end area developing maximum force.

TECHNICAL DATA NOTE: DATA MAY VARY BY CONFIGURATION. SEE CONFIGURATION SECTION.

Body Type	Sandwich
Interface	ISO 03
Capacity	10 gpm
Body Features	A to B or B to A
Seal Plate Included (see notes)	Yes
Stack Height	1.75 in.

- NOTES:**
- Customer to install locating pin (included) for functional orientation desired.
 - Stack height value in technical data table includes seal retainer plate.
 - For detailed information regarding the cartridges contained in this assembly, click on the models codes shown in the Included Components tab.
 - **Important:** Carefully consider the maximum system pressure. The pressure rating of the manifold is dependent on the manifold material, with the port type/size a secondary consideration. Manifolds constructed of aluminum are not rated for pressures higher than 3000 psi (210 bar), regardless of the port type/size specified.

OPTION SELECTION EXAMPLE: YDCALHNAA

CONTROL	(L) FUNCTIONAL SETTING RANGE	(H) SEAL MATERIAL	(N)
L Standard Screw Adjustment	H 1000 - 4000 psi w/25 psi Check (70 - 280 bar w/ 1,7 bar Check), 3000 psi (210 bar) Standard Setting	N Buna-N	
C Tamper Resistant - Factory Set	A 1000 - 4000 psi w/4 psi Check (70 - 280 bar w/ 0,3 bar Check), 3000 psi (210 bar) Standard Setting	V Viton	
	B 400 - 1500 psi w/4 psi Check (28 - 105 bar w/ 0,3 bar Check), 1000 psi (70 bar) Standard Setting		
	I 400 - 1500 psi w/25 psi Check (28 - 105 bar w/ 1,7 bar Check), 1000 psi (70 bar) Standard Setting		

PRIMARY CARTRIDGE	(A)
A A (with CBCA primary cartridge, 3:1 pilot ratio, standard capacity counterbalance valve)	
A A (with CBCAX primary cartridge, Fixed setting, 3:1 pilot ratio, standard capacity counterbalance valve)	

INCLUDED COMPONENTS

Part	Description	Quantity
500-001-012*	O-Ring	4
700-002*	Seal Plate	1
811-001-006*	Pin	1
850-004-218*	Plug	2
CBCALHN	Cartridge - Primary	1
CODAXEN	Cartridge	1

TECHNICAL FEATURES

- Capacity refers to pump flow or regeneration flow, which is the flow coming out of the rod side of the cylinder, whichever is larger
- The capacity may be determined by the passages dictated by the sandwich pattern rather than the cartridge capacity.
- This valve assembly will not prevent a load from extending the cylinder. The best way to prevent this is to use a vented counterbalance valve mounted directly to the rod end of the cylinder. A non-vented valve will not work.
- The ideal cylinder ratio to use with regeneration is 2:1, the blind end area being twice what the annular area at the rod end. A 2:1 cylinder in regen gives the same speed extending as retracting.
- Cylinders with ratios above 2:1 (large rods) will function correctly but with less speed gain. Intensification needs to be considered with higher ratios. A 2:1 cylinder may generate a pressure on the rod side that is twice system pressure unless steps are taken to limit it.
- Cylinders with ratios as low as 1.5:1 (small rods) may work if care is used in designing the application. As the rod diameter gets smaller in relation to the piston diameter the flows increase dramatically and the force available drops accordingly.
- Cylinders with ratios below 1.5:1 are unlikely to result in a working regenerative application because of the small area of the rod and the high flows that would be generated.
- When a cylinder is in the regenerative mode the only force available is the pressure working on the rod area.

- The counterbalance valve in this assembly is not acting as a counterbalance valve; it is acting as a pressure sensitive unloading valve. The setting, however, relates to the counterbalance world. With the CB*A set at 4000 psi (280 bar), the circuit will start to come out of regen with about 1000 psi (70 bar) of blind end pressure and will then start to gain force somewhere above 1400 psi (90 bar).
- Regeneration is only possible in the extend direction.

MANIFOLD FACES

FACE GRID

1	2	3	4
5	6	7	8
9	10	11	12

FACE 2

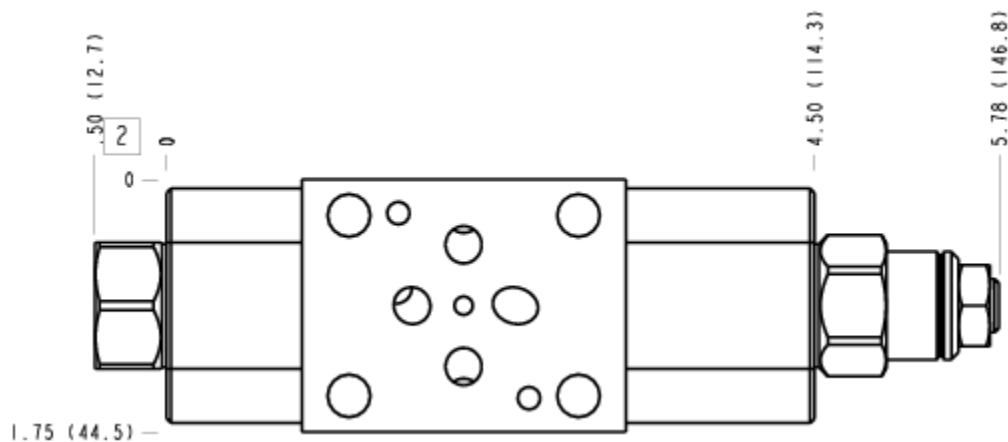

FACE 5

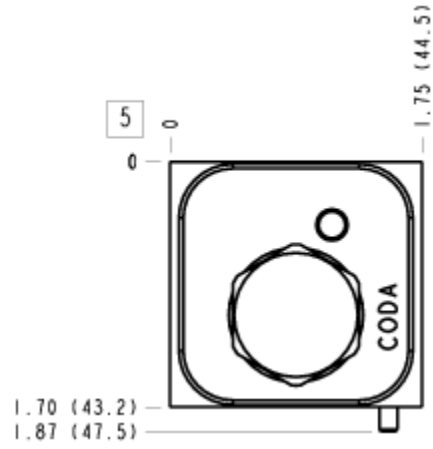

FACE 6

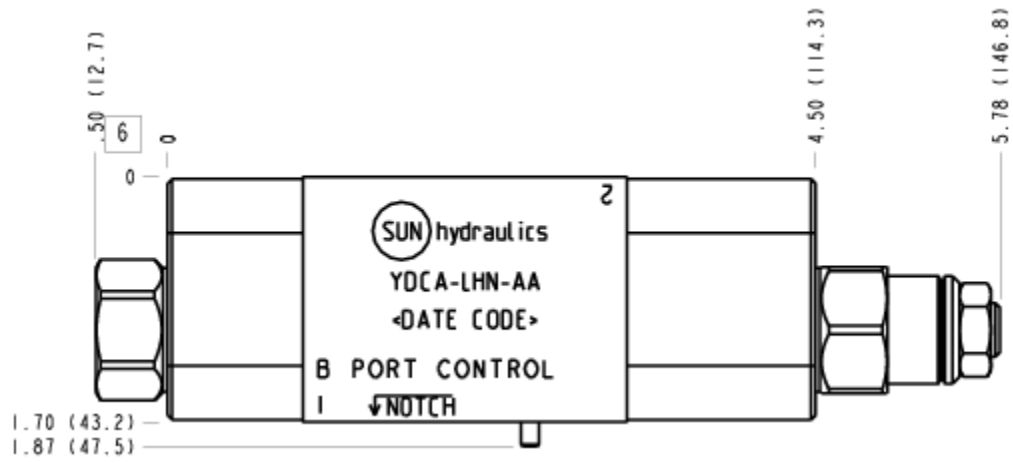

FACE 7

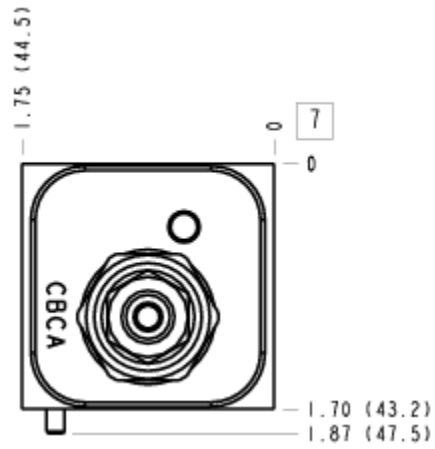

FACE 8

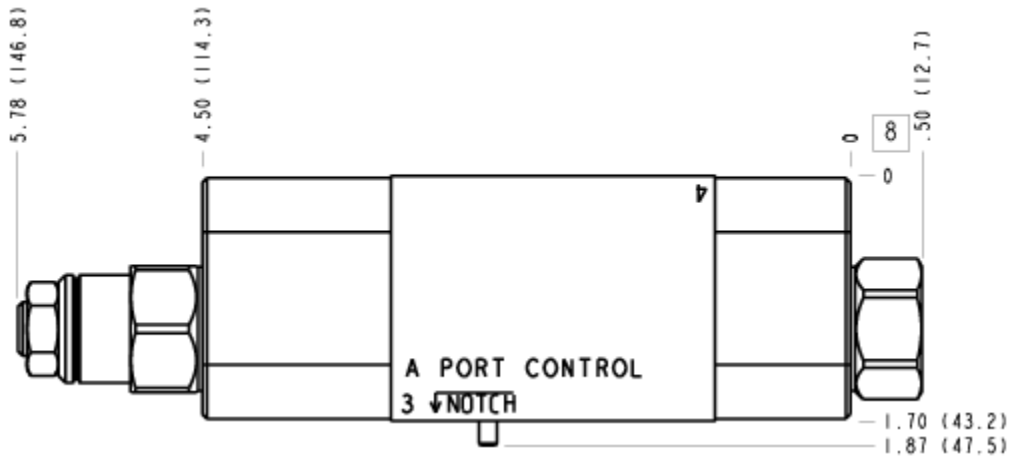

FACE 10

