

The full time regenerative valve assembly allows a double-acting, single rod cylinder to be extended more rapidly using the same pump flow. To achieve this, oil from the rod end of the cylinder (CR) is added to the pump flow to the blind end (CH), increasing the rate of extension. VR is the connection to the retract side of the directional valve.

TECHNICAL DATA NOTE: DATA MAY VARY BY CONFIGURATION. SEE CONFIGURATION SECTION.

Body Type	Line mount
Capacity	30 gpm
Mounting Hole Diameter	.42 in.
Mounting Hole Depth	Through
Mounting Hole Quantity	2

- NOTES:**
- **Important:** Carefully consider the maximum system pressure. The pressure rating of the manifold is dependent on the manifold material, with the port type/size a secondary consideration. Manifolds constructed of aluminum are not rated for pressures higher than 3000 psi (210 bar), regardless of the port type/size specified.
 - For detailed information regarding the cartridges contained in this assembly, click on the models codes shown in the Included Components tab.

OPTION SELECTION EXAMPLE: YDEPXCNAL

CONTROL	(X) CRACKING PRESSURE	(C) SEAL MATERIAL	(N)
X Not Adjustable	C 30 psi (2 bar)	N Buna-N	
	A 4 psi (0,3 bar)	V Viton	
	B 15 psi (1 bar)		
	D 50 psi (3,5 bar)		
	F 100 psi (7 bar)		
	Z 1 psi (0,07 bar)		

PRIMARY CARTRIDGE (A)

A A (with CXEE primary cartridge, Free flow side to nose check valve with port 3 blocked)
--

INCLUDED COMPONENTS

Part	Description	Quantity
COFAXEN	Cartridge	1
CXEEXCN	Cartridge - Primary	1

TECHNICAL FEATURES

- Capacity refers to pump flow or regeneration flow, which is the flow coming out of the rod side of the cylinder, whichever is larger
- This valve assembly will not prevent a load from extending the cylinder. The best way to prevent this is to use a vented counterbalance valve mounted directly to the rod end of the cylinder. A non-vented valve will not work.
- The ideal cylinder ratio to use with regeneration is 2:1, the blind end area being twice what the annular area at the rod end. A 2:1 cylinder in regen gives the same speed extending as retracting.
- Cylinders with ratios above 2:1 (large rods) will function correctly but with less speed gain. Intensification needs to be considered with higher ratios. A 2:1 cylinder may generate a pressure on the rod side that is twice system pressure unless steps are taken to limit it.
- Cylinders with ratios as low as 1.5:1 (small rods) may work if care is used in designing the application. As the rod diameter gets smaller in relation to the piston diameter the flows increase dramatically and the force available drops accordingly.
- Cylinders with ratios below 1.5:1 are unlikely to result in a working regenerative application because of the small area of the rod and the high flows that would be generated.
- When a cylinder is in the regenerative mode the only force available is the pressure working on the rod area.
- Regeneration is only possible in the extend direction.

MANIFOLD FACES

FACE GRID

1	2	3	4
5	6	7	8
9	10	11	12

FACE 2

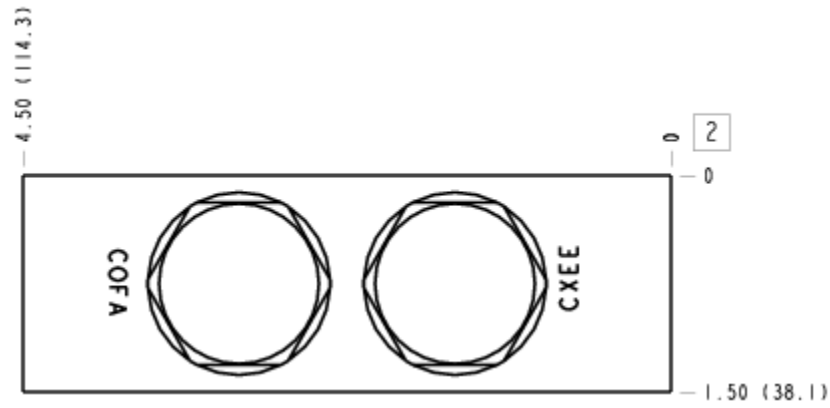

FACE 5

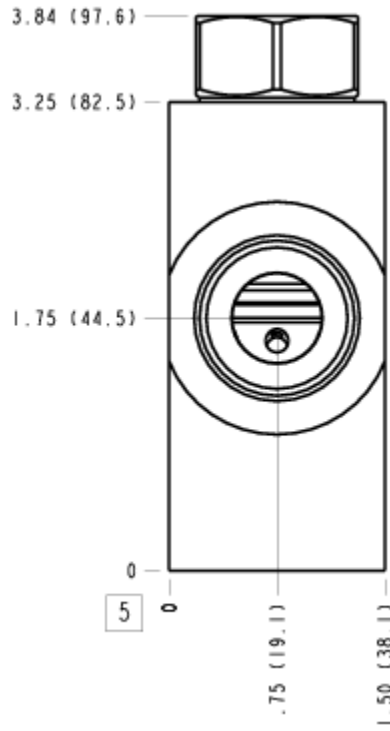

FACE 6

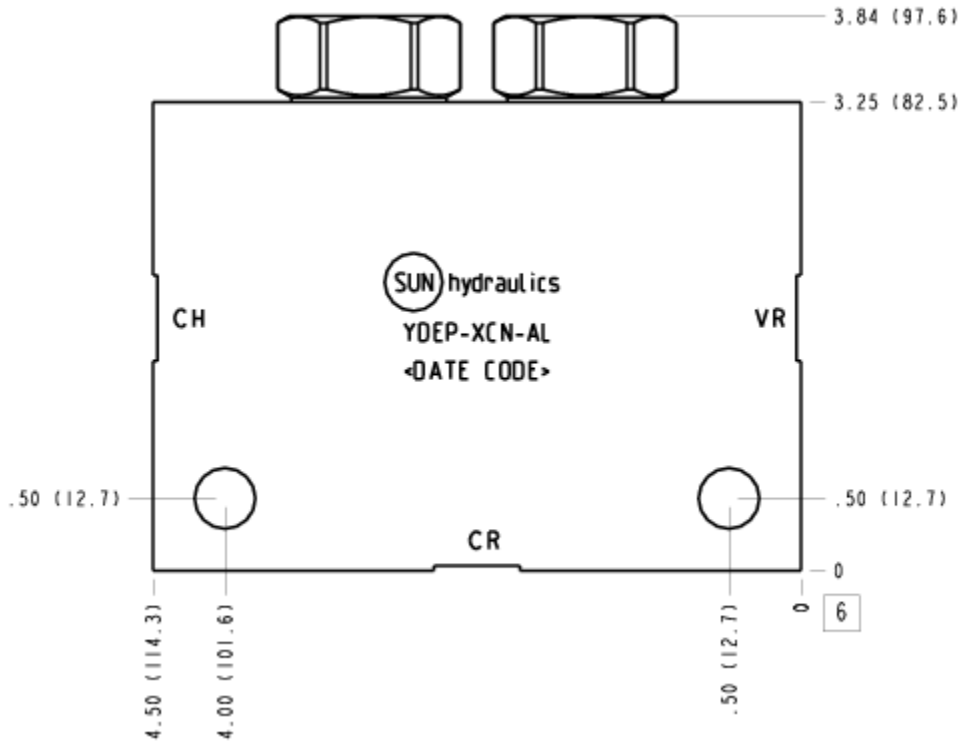

FACE 7

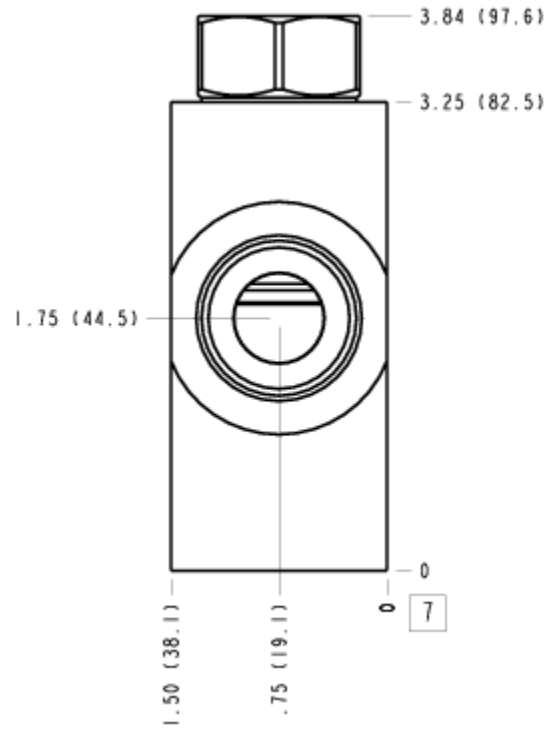

FACE 10

