

This valve assembly consists of a normally-closed bypass style compensator on the P port and a shuttle that senses pressure from the higher of the 2 work ports. Its purpose is to provide a relatively constant pressure drop across the directional valve thus isolating the directional valve spool from high flow forces. This is accomplished by bypassing the excess oil to the T port. The constant drop creates a pressure compensated flow control out of the directional valve.

TECHNICAL DATA NOTE: DATA MAY VARY BY CONFIGURATION. SEE CONFIGURATION SECTION.

| | |
|---------------|------------|
| Body Type | Sandwich |
| Interface | ISO 08 |
| Capacity | 120 gpm |
| Body Features | Meter in P |

- NOTES:**
- **Important:** Carefully consider the maximum system pressure. The pressure rating of the manifold is dependent on the manifold material, with the port type/size a secondary consideration. Manifolds constructed of aluminum are not rated for pressures higher than 3000 psi (210 bar), regardless of the port type/size specified.
 - For detailed information regarding the cartridges contained in this assembly, click on the models codes shown in the Included Components tab.

OPTION SELECTION EXAMPLE: YFICXHNCA

| CONTROL | | (X) DIFFERENTIAL PRESSURE | (H) SEAL MATERIAL | (N) | |
|----------|-------------------|---------------------------|--------------------|----------|--------|
| X | Not Adjustable | H | 200 psi (14 bar) | N | Buna-N |
| L | Tuning Adjustment | D | 50 psi (3,5 bar) | V | Viton |
| | | F | 100 psi (7 bar) | | |
| | | G | 150 psi (10,5 bar) | | |

| PRIMARY CARTRIDGE | | (C) |
|-------------------|--|-----|
| C | C (with LRJC primary cartridge, Normally closed, modulating element) | |

INCLUDED COMPONENTS

| Part | Description | Quantity |
|---------------|---------------------|----------|
| 500-001-114* | O-Ring | 2 |
| 500-001-121* | O-Ring | 4 |
| 811-001-002* | Locating Pin | 1 |
| A330-006-004* | SAE Plug | 1 |
| CSABXXN | Cartridge | 1 |
| LRJCXHN | Cartridge - Primary | 1 |

TECHNICAL FEATURES

- This assembly is meant to be used in a single station circuit with a fixed displacement pump.
- The pressure differential across the orifice (directional valve) varies with bypass flow and system pressure. It is at its lowest at zero bypass flow and increases with increasing bypass flow and system pressure.
- Another term for this assembly is a hydrostat.

MANIFOLD FACES

FACE GRID

| | | | |
|---|----|----|----|
| 1 | 2 | 3 | 4 |
| 5 | 6 | 7 | 8 |
| 9 | 10 | 11 | 12 |

FACE 2

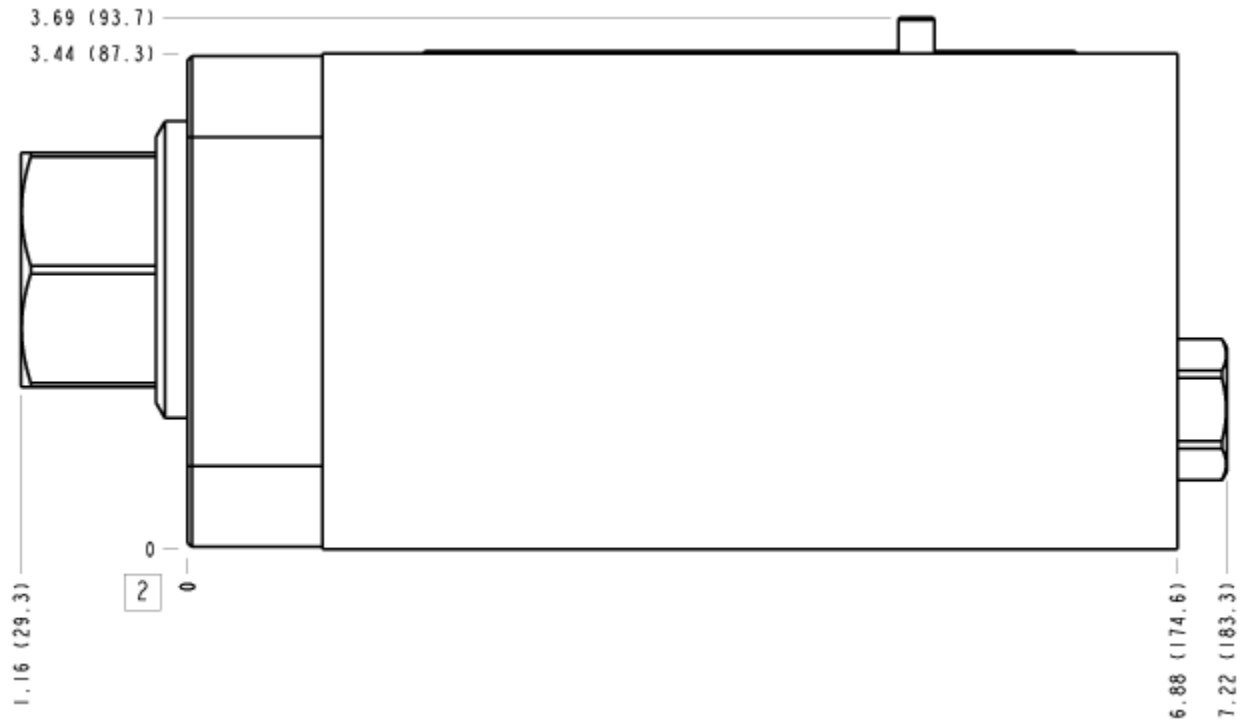

FACE 5

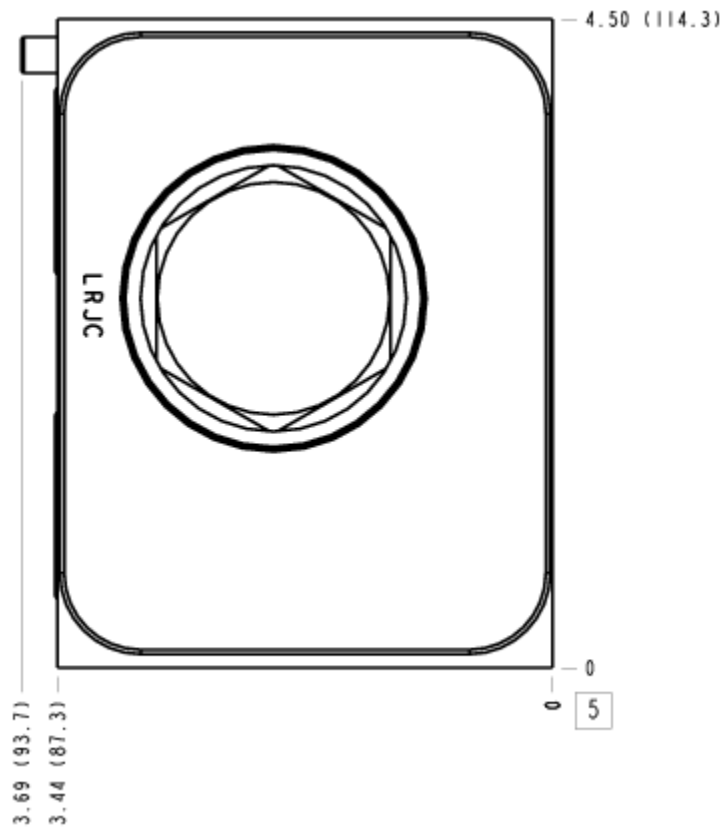

FACE 6

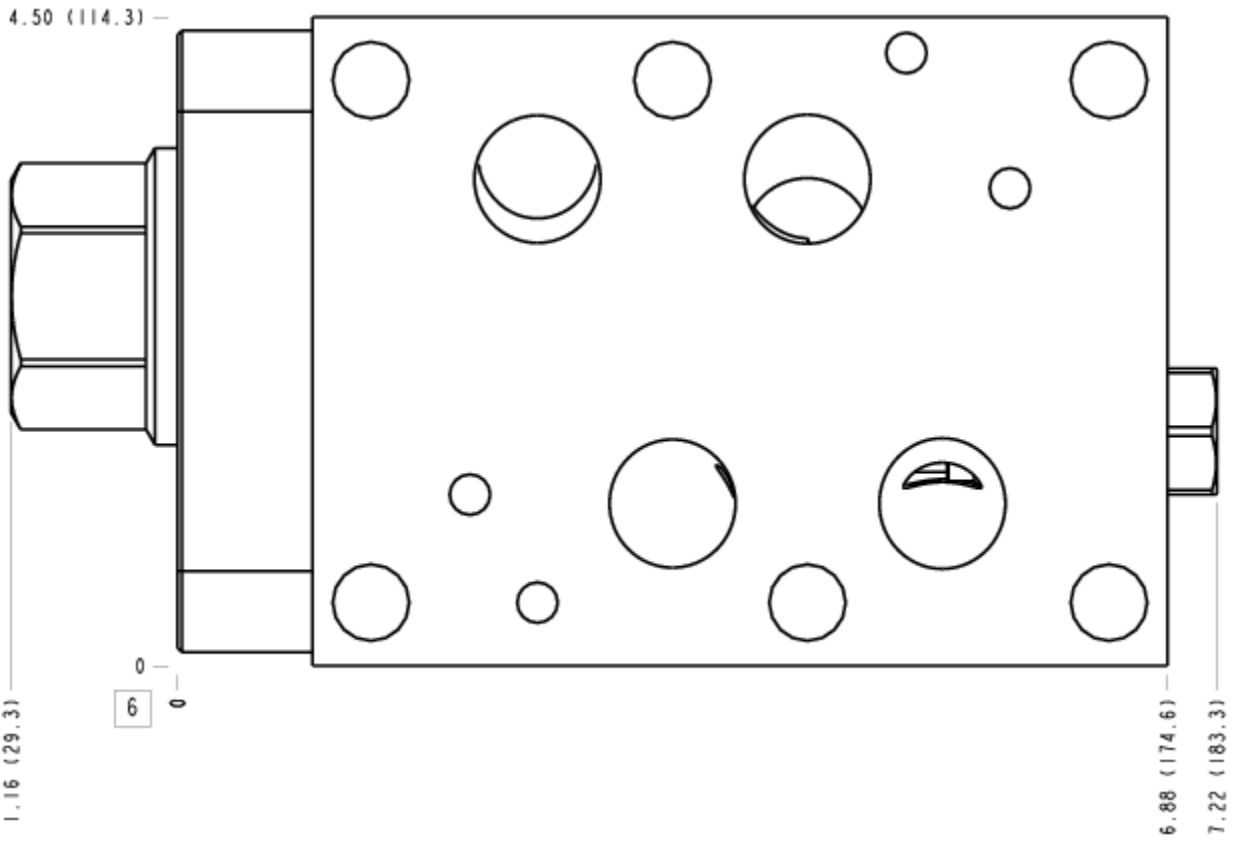

FACE 7

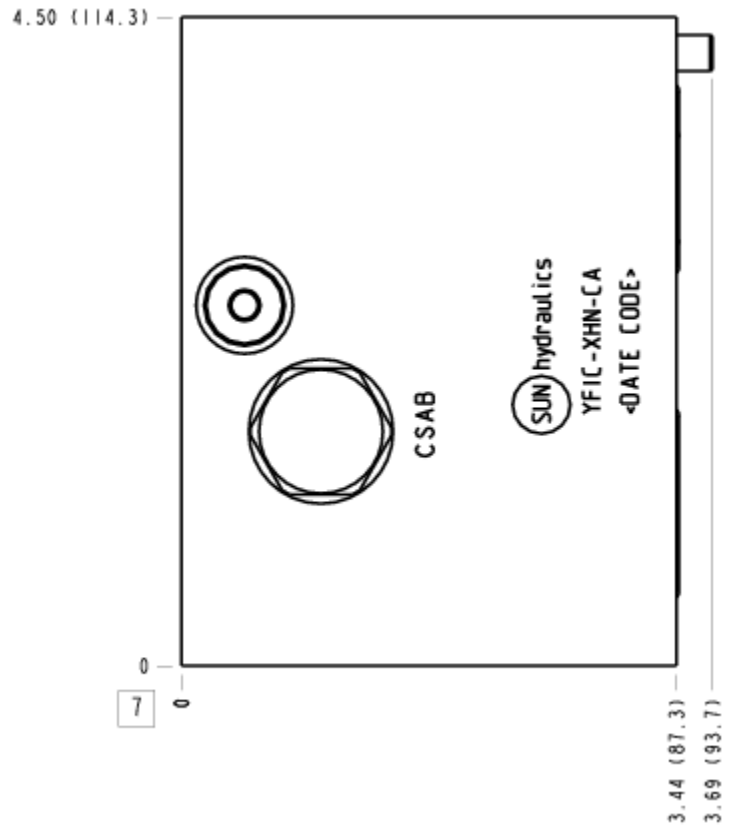

FACE 8

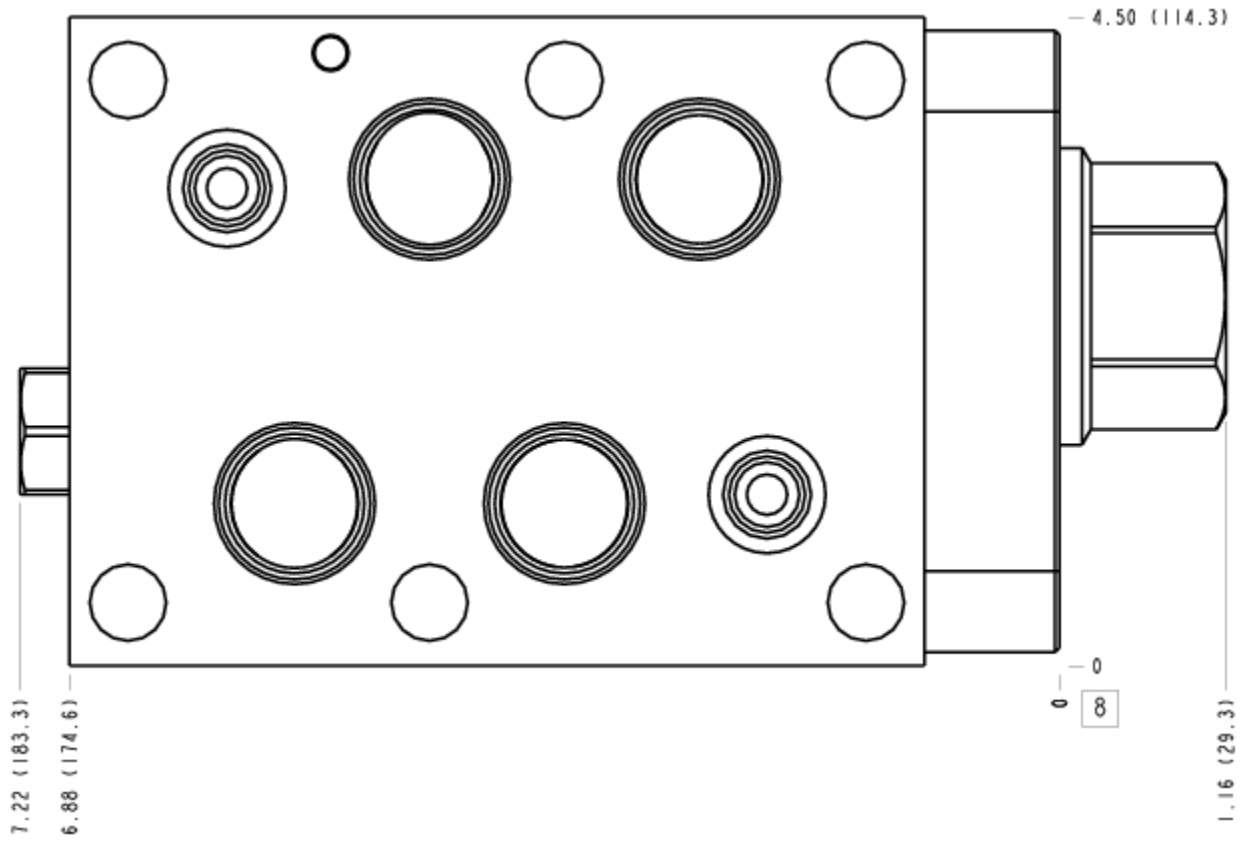

FACE 10

